

# Coburn Centafold & Foldaside



# Foldaside and Centafold Door Systems

## FOR INTERIOR FOLDING PARTITIONS



A comprehensive range of sliding door fittings for timber folding partitions either top hung or bottom rolling with end or centrally hung door leaves.

The door gears detailed in this catalogue, with the exception of Foldaside 210 and Foldaside 310, are not normally suitable for exterior openings as rebated heads and cills cannot be used. See separate catalogue for full range of exterior Foldaside and Cornaway Door Systems.

All standard Foldaside and Centafold hangers are of steel construction with ball bearings lubricated for life. Hangers and guides, except those used on Foldaside 210 and 310, are fitted to the top and edges of the door leaves and are therefore concealed when the partition is closed across the opening. In many instances opening widths are unlimited but individual door leaves are restricted to between 700 to 900mm wide on Foldaside end hung doors and between 700 to 1200mm wide on Centafold centre hung doors. With the Foldaside system, usually up to 8 leaves may be hinged together with the end leaf hinged to jamb. “Loose” or “floating” suites of door leaves are not recommended with interior Foldaside Door Gear except Foldaside 210 pages 24-25 and Foldaside 310 pages 26-27. With the Centafold system up to 7½ leaves may be hinged together with end half leaf hinged to jamb. “Loose” or “floating” suites of five or seven leaves may be used with top hung systems only. See the pages relating to the gear concerned for complete details of maximum sizes.

All performance recommendations apply to the gear only and specifiers and purchasers must satisfy themselves that the building structures are adequate for the door weights and will allow the specified working clearances to be maintained under all conditions. All loadings given are based on doors subjected to normal manual usage under normal conditions.

Complete folding partitions and sound reducing movable walls are also available from Hillaldam Coburn Limited on a supply and fix basis.

## Index

### FOLDASIDE SLIDING DOOR SYSTEMS FOR END HUNG FOLDING PARTITIONS

Maximum Door Height m	Max. Weight Per Leaf kg	Gear Number	Page Numbers
2.5	27	100	6-7
2.4	36	240	8-9
2.4	36	210	24-25
2.4	45	642*	14-15
3.0	45	340	10-11
3.3	50	340	10-11
3.6	55	340	10-11
3.0	45	310	26-27
3.3	50	310	26-27
3.6	55	310	26-27
3.6	75	640*	12-13

### CENTAFOLD SLIDING DOOR SYSTEMS FOR CENTRE HUNG FOLDING PARTITIONS

2.5	27	100	16-17
2.7	36	250	18-19
3.0	55	350	20-21
3.3	60	350	20-21
3.6	65	350	20-21
3.6	60	644*	22-23

\*Bottom rolling systems where weight of doors is carried on bottom track.

# Top Track Brackets

## DESIGN

Brackets have been designed to perform to all maximum carrying capacities shown in this catalogue under all normal conditions. For unusual and mechanically operated doors consult HILLALDAM COBURN.

## MATERIALS

All brackets are either aluminium, forged or pressed steel.

## JOINT AND END BRACKETS

The 100 type of side fixing brackets for all tracks have a detachable lock-joint kit to convert the ordinary plain bracket, and most types of brackets for 2-16, 3-20 and 3-25 tracks have detachable end plates which convert plain brackets to any hand of closed end.

## SINGLE TRACK SIDE FIXING BRACKETS

- Type - 100 Open bracket.
- 051 Closed end piece to convert 2-100 & 3-100 open brackets to any hand of closed end.
- 002 Lock joint plate to convert 2-100 & 3-100 open brackets to lock joint brackets.

Track No.	A	B	C	C	D	E	H
	mm	mm	Open/ Closed mm	Lock Joint mm	mm	mm	Bolt Dia mm
2-16	92	50	49	49	76	25	10
3-20	121	67	60	60	102	35	12
3-25							

## UNIVERSAL SOFFIT FIXING BRACKETS

- Type - 150 Open bracket.
- 051 Closed end piece to convert open bracket to any hand of closed end.
- 152 lock joint bracket.

Track No.	A	B	C	D	H
	mm	mm	mm	mm	Bolt Dia mm
2-16	70	45	45	90	8
3-20	94	58	57	115	10
3-25					

## SOFFIT FIXING BRACKETS

- Type - 190 Plain and
- 192 Lock joint.

Track No.	A	B	C	H
	mm	mm	mm	Bolt Dia mm
2-16	65	44	44	10
3-20	87	58	57	12
3-25				

FINISH: All steel brackets are supplied zinc plated

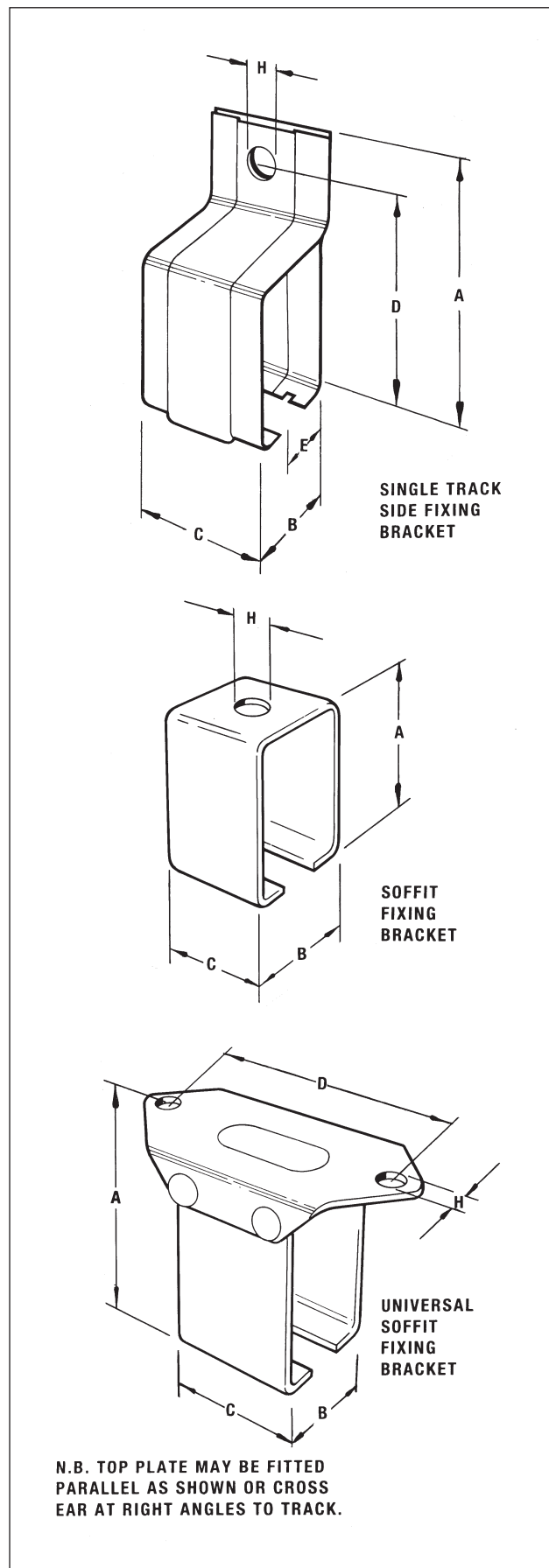

# Top Track Bracket Spacings

## BRACKET SPACING FOR STANDARD LENGTHS OF 2-16, 3-20 AND 3-25 TRACK

Side or soffit fixing top track brackets are available for all top hung systems using tracks 2-16, 3-20 and 3-25 which must have track supporting brackets positioned at the centres shown.

With Foldaside 640 and Centafold 644 bottom rolling systems, the track is normally screwed direct to the timber soffit – see drawing details pages 13 and 23.

Closed end brackets should be fitted at the end of each track run and lock-joint brackets at each track joint. In addition, intermediate open brackets are required on each track length to maintain the bracket centres at a maximum of 900mm. The number of intermediate open brackets per track length are scheduled below.

- 1.8m Track length = 1 intermediate open bracket.
- 2.1m Track length = 2 intermediate open brackets.
- 2.4m Track length = 2 intermediate open brackets.
- 3.0m Track length = 3 intermediate open brackets.

All Foldaside and Centafold top hung systems require an extra bracket fitted where the concentrated weight of the folded doors is carried when in the open parked position.

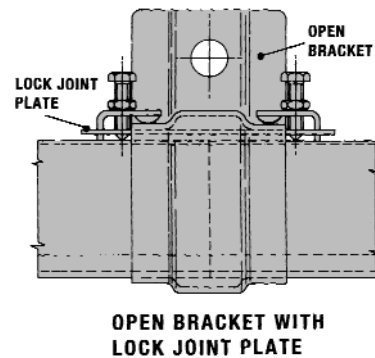
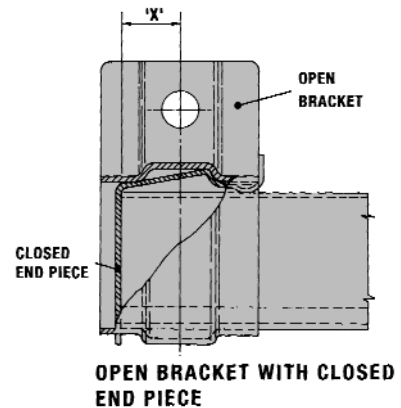

### BRACKET SPACINGS

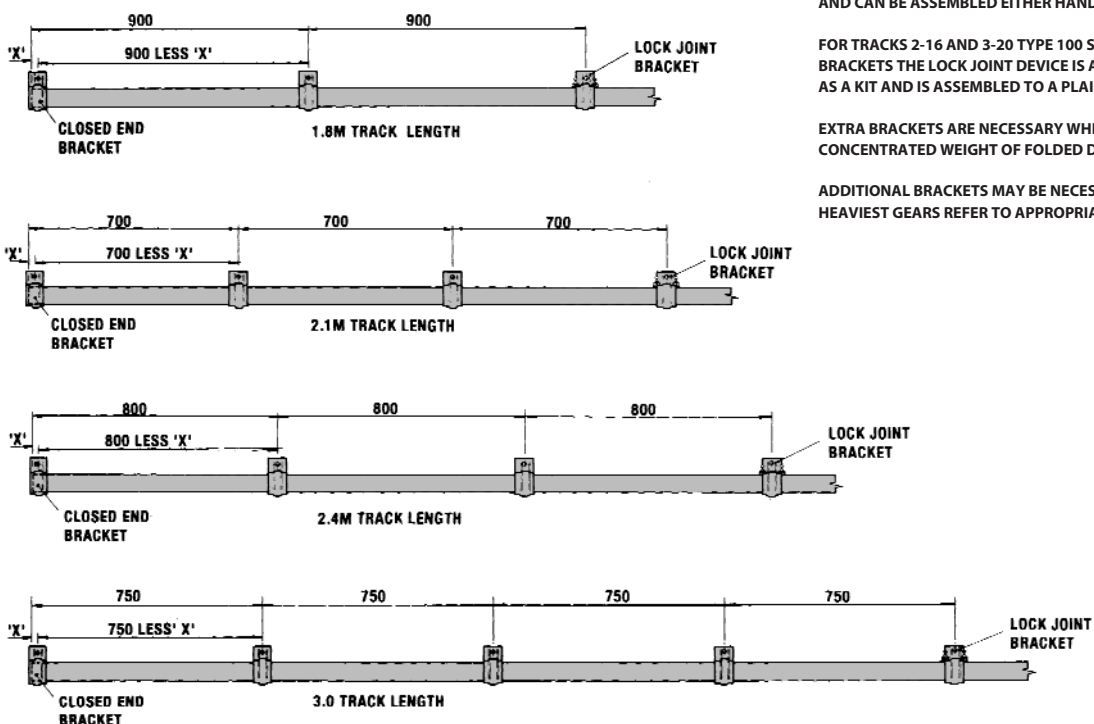

FOR TRACKS 2-16, 3-20, 3-25  
CLOSED END PLATES ARE SENT SEPARATELY  
AND CAN BE ASSEMBLED EITHER HAND.

FOR TRACKS 2-16 AND 3-20 TYPE 100 SIDE WALL  
BRACKETS THE LOCK JOINT DEVICE IS ALSO SUPPLIED  
AS A KIT AND IS ASSEMBLED TO A PLAIN BRACKET.

EXTRA BRACKETS ARE NECESSARY WHERE A  
CONCENTRATED WEIGHT OF FOLDED DOORS IS CARRIED.

ADDITIONAL BRACKETS MAY BE NECESSARY WITH  
HEAVIEST GEARS REFER TO APPROPRIATE DRAWING.

# Door Furniture for Interior Folding Partitions



EXTRUDED ALUMINIUM  
80 x 20mm  
**95-622**  
DOOR PULL

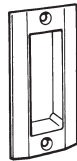

PRECISION DIE CAST  
100 x 50mm  
SATIN CHROME  
**95-617**  
FLUSH HANDLE



ALUMINIUM, CAST,  
65 x 65mm. WHEN USED  
WITH 95-658 MORTICE LATCH  
MINIMUM DOOR  
THICKNESS 38mm S.A.A.  
**95-631**  
FLUSH RING  
HANDLE



ALUMINIUM CAST  
130 x 65mm  
KEYHOLE/FOLLOWER CENTRES  
57mm. WHEN USED WITH  
95-646 AND 95-647  
MORTICE LOCKS, MINIMUM  
DOOR THICKNESS 38mm S.A.A.  
**95-633**  
FLUSH RING  
HANDLE

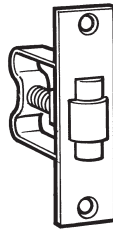

BRASS, BALL BEARING ROLLER  
ADJUSTABLE SHOOT  
FLAT BRASS FOREND  
75 x 22mm  
**95-667**  
ROLLER CATCH

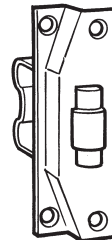

BRASS, BALL BEARING ROLLER  
ADJUSTABLE SHOOT  
REBATED BRASS FOREND  
**95-668**  
REBATED  
ROLLER CATCH



BRASS BOLT AND FOREND.  
FLAT FOREND, 140 x 30mm  
STEEL CASE. DEPTH 64mm  
HEIGHT 70mm THICKNESS  
14mm BACKSET 43mm  
**95-657**  
MORTICE LATCH



BRASS BOLT AND FOREND  
HALF REBATED FOREND  
157 x 27 x 13mm. STEEL CASE  
DEPTH 75mm. HEIGHT 70mm.  
THICKNESS 14mm  
BACKSET 60mm  
**95-658**  
REBATED  
MORTICE LATCH



BRASS BOLT AND FOREND.  
3 LEVERS. FLAT FOREND,  
152 x 25mm. STEEL CASE  
DEPTH 64mm. HEIGHT 108mm  
THICKNESS 14mm  
BACKSET 44mm  
KEYHOLE/FOLLOWER CENTRES  
57mm  
**95-646**  
MORTICE LOCK



BRASS BOLT AND FOREND  
3 LEVERS. HALF REBATED FOREND,  
120 x 30 x 13mm. STEEL  
CASE. DEPTH 50mm. HEIGHT  
70mm. THICKNESS 14mm  
BACKSET 57mm. KEYHOLE/FOLLOWER  
CENTRES 57mm  
**95-647**  
REBATED  
MORTICE LOCK



**FLUSH BOLTS** 150 x 40mm  
95-669 (GAA) 95-675 (SAA)  
**FLUSH BOLTS** 190 x 40mm  
95-670 (GAA) 95-677 (SAA)  
**CRANKED SHOOTS** 190 x 40mm  
95-679 (SAA) 95-671 (GAA)



EXTRUDED ALUMINIUM  
ANODISED FINISH  
**95-582**  
FLOOR BOLT

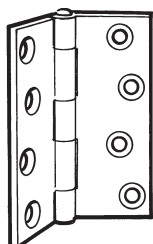

**STEEL BUTT  
HINGES**  
BRIGHT FINISH  
**95-520** 75 x 50mm  
**95-524** 102 x 67mm  
**95-526** 100 x 75mm  
**95-530** 100 x 100mm

**ALUMINIUM  
BUTT HINGES**  
S.A.A. FINISH  
**95-541** 75 x 50mm  
**95-545** 102 x 67mm  
**95-547** 100 x 75mm

**BRASS  
BUTT HINGES**  
SATIN CHROME FINISH  
100 x 100mm  
**95-551**  
ALL HINGES SPECIALLY  
DRILLED FOR  
FOLDING DOORS  
ALUMINIUM  
HINGES PROVIDED  
WITH STAINLESS  
STEEL WASHERS  
AND PINS

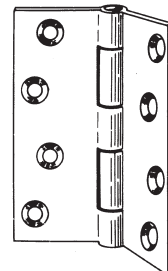

# Foldaside 100 Sliding Door Systems

## FOR INTERIOR END HUNG FOLDING DOORS USING EQUAL WIDTH DOOR LEAVES

### APPLICATION

Top hung, end folding, light weight interior residential and commercial doors with concealed fixing for hangers and pivots.

### RANGE

Maximum leaf weight 27kg (60lbs)

Maximum leaf height 2.5m

Maximum leaf width 600mm

Leaf thickness between 20 to 40mm. Swing leaves may not be used. Up to 4 leaves may be hinged together with end leaf pivoted adjacent to jamb. In situations where a greater degree of stability is required, bottom guiding with floor channel should be used. For door leaves over 450mm wide and/or over 15kg in weight, bottom guiding must be employed, minimum leaf thickness 30mm.

### DOOR CONSTRUCTION

Solid blockboard, louvred or flush panelled construction with adequate provision for fixing end pivots and hangers.

### TRACK

1-12 (1.2mm) Galvanised steel to BS EN 10142. Drilled for brackets or soffit fixing. Lengths 1.5m to 3.0m. Extruded aluminium track available as an optional extra.

### TRACK BRACKETS

1-100 Steel, side fixing with two screws.

### HANGERS

1-246 Steel construction. 4 nylon wheels, ball bearings lubricated for life. Vertical adjustment.

### HINGES

95-521 Steel, plated finish. Surface mounted. 3 per joint for doors up to 2.1m high. 4 per joint recommended for higher doors.

### TOP AND BOTTOM PIVOTS

95-508 Pressed steel top housing, clamp fixing in track. Spring loaded pivot fixed to top edge of door. Bottom pivot and housing, pressed steel with nylon socket slide. Vertical and lateral adjustment.

### DOOR GUIDE

41-346 Steel plate, nylon swivel.

### FLOOR CHANNEL

41-2 aluminium. Drilled and countersunk for woodscrew fixing. Lengths 1.5m to 3.0m.

### FURNITURE

A range of furniture is shown on page 5.

### FINISHES

Top track galvanised. Hangers, brackets, guides and pivots zinc plated. Furniture usually satin anodised.

## STANDARD PACKSETS FOR FOLDASIDE DOOR ARRANGEMENTS TWO DOORS FOLDING - COMPONENT PACK 100-020

For Foldaside door arrangements. Comprising; 1 only 1-246 folding door hangers, 1 set 95-508 top and bottom pivots, 3 only 95-521 hinges, 1 only 95-622 door pull, spanner, installation details and all screws.

## FOUR DOORS FOLDING - COMPONENTS PACK 100-040

For Foldaside door arrangements. Comprising; 2 only 1-246 folding door hangers, 1 set 95-508 top and bottom pivots, 9 only 95-521 hinges, 2 only 95-622 door pulls, spanner, installation details and all screws.

### TOP TRACK

available in the following standards lengths:

1-12-15 length 1.5m 1-12-24 length 2.4m

1-12-18 length 1.8m 1-12-30 length 3.0m

1-12-21 length 2.1m

### SIDE FIXING TRACK BRACKET PACKS

1-005 comprising 5 bracket with fixing screws for track lengths 1.5m, 1.8m or 2.1m.

1-008 comprising 8 brackets with fixing screws for track lengths 2.4m or 3.0m

### BOTTOM GUIDING 41-346

door guides with 41-2 channel in lengths to match top track.

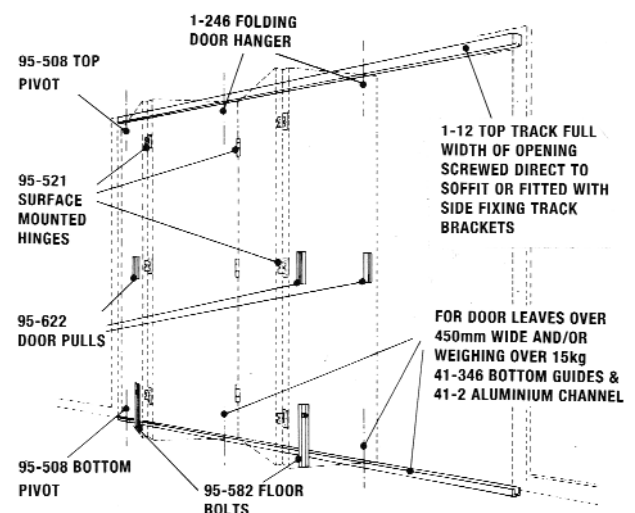



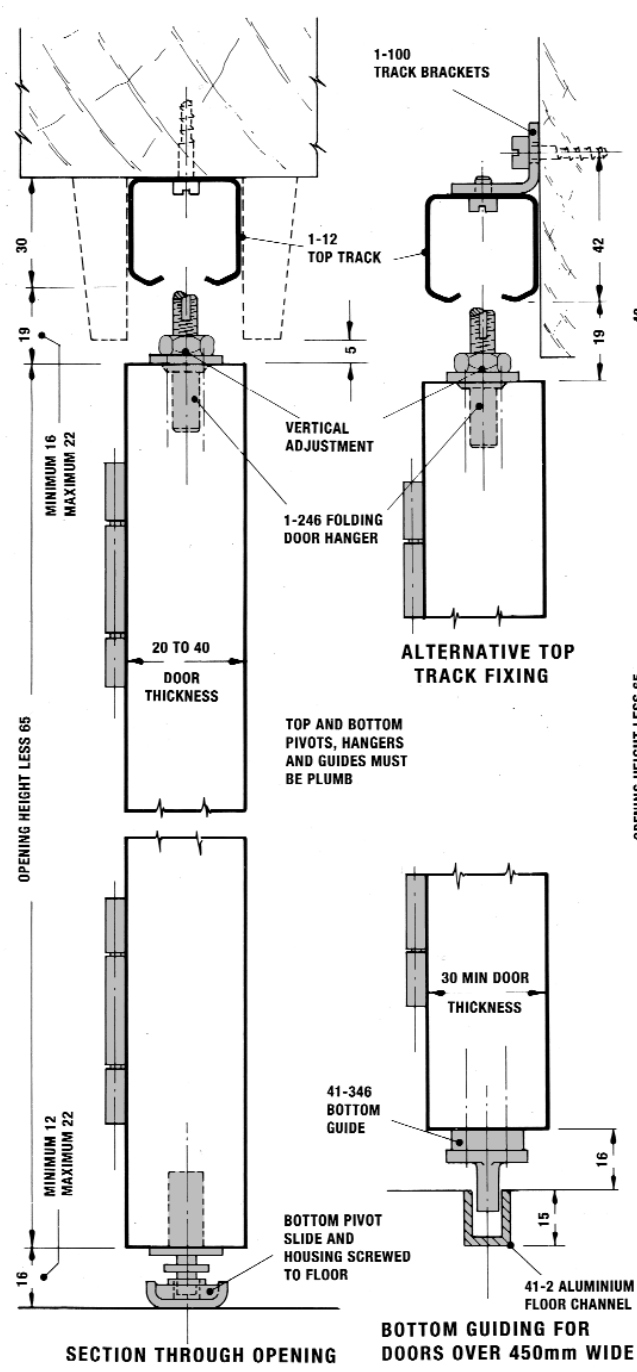

STANDARD TRACK LENGTHS				
1.8	2.1	2.4	3.0	METRES

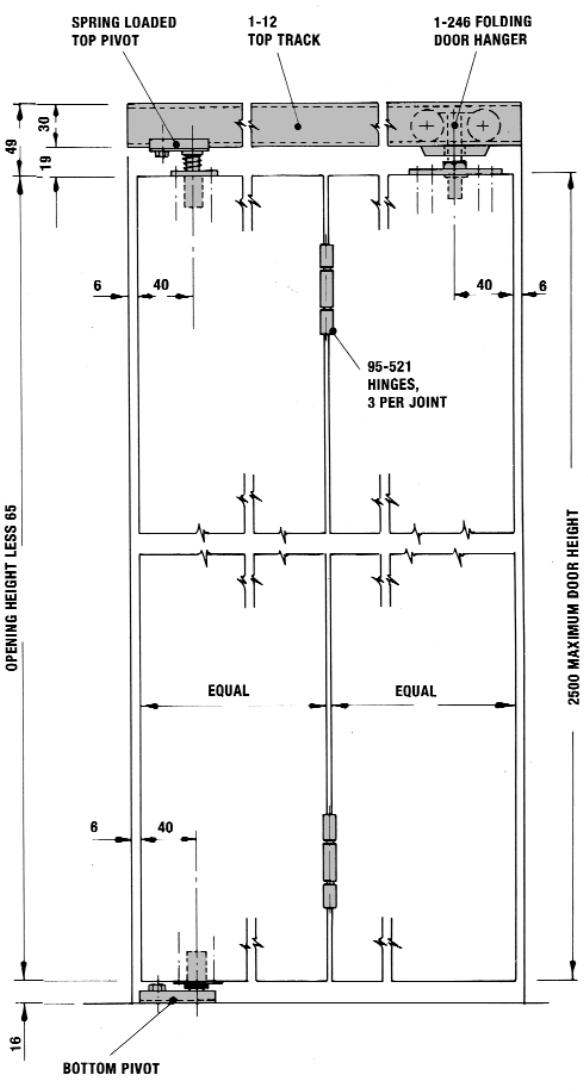

ELEVATION 2 LEAVES FOLDING TO ONE SIDE

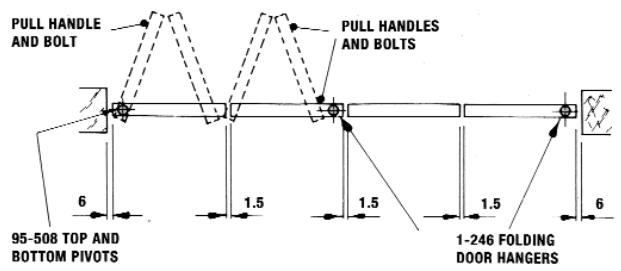

PLAN SHOWING FOUR LEAVES FOLDING TO ONE SIDE

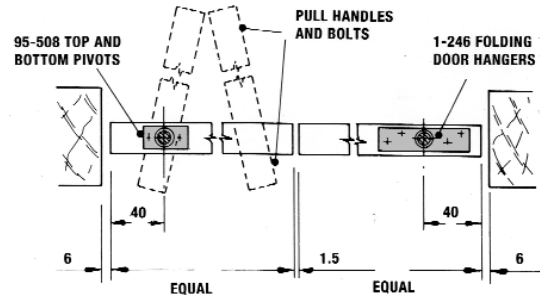

PLAN SHOWING TWO LEAVES FOLDING TO ONE SIDE

# Foldaside 240 Sliding & Folding Door Systems

## FOR TOP HUNG FOLDING PARTITIONS

### APPLICATION

Top hung, light duty, internal folding doors with concealed fittings. For residential applications, etc.

### RANGE

Maximum door weight 36kg (80lb)  
 Maximum door height 2.4m (8ft)  
 Maximum opening width 12.8m (42ft)  
 Maximum door leaf width 800mm (2ft 8in)

Up to 8 leaves may be hinged together. Loose or floating suites of door leaves are not recommended, alternatively use Foldaside 210 pages 24-25.

### DOOR CONSTRUCTION

Door thickness 35 to 44mm. Width of door leaves vary according to arrangements; refer to drawings for details. Rebating to suit hanger aprons is shown. Swing leaves are best hinged to jambs. When hinged to folding suites reduce door leaf widths to 700mm and use four wheel hangers adjoining 'swinger'. Always engage holdback catch before operating.

### FIXING

Track brackets usually soffit fixed. Universal soffit bracket designed for ease of fixing and versatility. Additional brackets required where doors fold. All hangers have vertical adjustment.

Floor channel unnecessary under swing leaves.

### HANGERS

All steel, ball bearing lubricated for life. 2-240 with two wheels. 2-241 with four wheels.

### TRACK

2-16 (1.6mm) Galvanised steel to BS EN 10142. Standard Lengths 1.8m to 3.0m.

### TRACK BRACKETS

Steel. See drawing and range on page 3.

### DOOR GUIDES

41-340 Steel angle plate fits rebate of door. Nylon swivel.

### FLOOR CHANNEL

41-2 Aluminium. Drilled and countersunk for timber. Lengths 1.8m to 3.0m.

### FOLDASIDE BUTT HINGES

95-520 Steel, size 75 x 50mm. 95-541 Aluminium, anodised with stainless washers and pins, size 75 x 50mm. All specially drilled.

### JAMB PIVOTS

95-518 Steel and brass jamb pivot set. For use with all equal width leaves.

### FURNITURE

A range of furniture is shown on page 5.

### FINISHES

Top track galvanised. Aprons, brackets and pivots, zinc plated. Furniture usually satin anodised.

### BOLTS AND SCREWS

Included with all fittings except track brackets.

**SPECIAL NOTE:** When Jamb pivots are replaced by hinges, particular attention should be paid by the joiner to leaf sizes and the use of Dimension A or B as shown on the opposite page.

## EXAMPLE

**QUANTITIES FOR A DOOR PARTITION 2.1m wide x 2.2m high. Weight of each leaf 30kg. Three leaves folding one way, end leaf hinged to jamb.**

### A TYPICAL BILL OF QUANTITIES

ITEM				
A	2-16	Track 1 x 1.8m	1.8	LIN.M
B	2-150	Bracket, open. soffit fixing	4	NO.
C	2-051	Closed end piece	1	PR.
D		Bolts for brackets (by others)	8	NO.
E	2-241	Hanger, four wheel	1	NO.
F	95-541	Foldaside aluminium hinges S.A.A.	3	PACKS
G	41-340	Bottom guide	1	NO.
H	41-2	Floor channel aluminium d/c/sk 1 x 1.8m	1.8	LIN.M
J	95-675	Flush bolt S.A.A.	1	NO
K	95-617	Flush handle S.C.	3	NO.
L	95-665	Holdback catch	1	NO.
M	95-633	Flush ring handles S.A.A.	2	NO.
N	95-646	Mortice lock	1	NO.

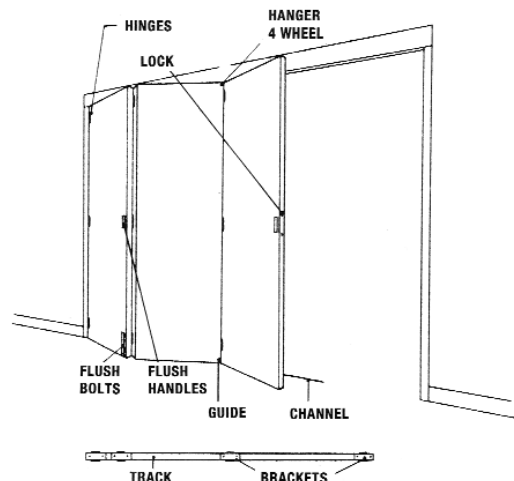



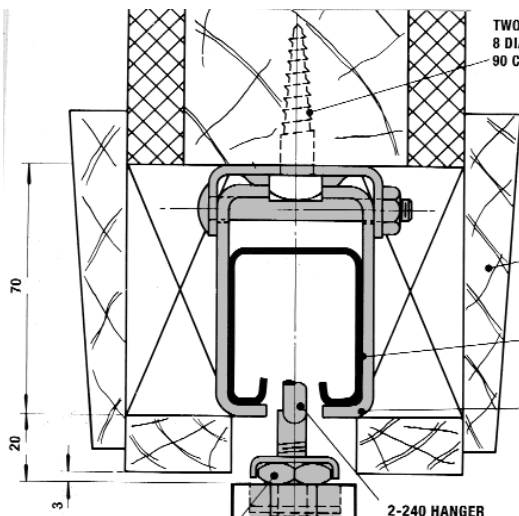

STANDARD TRACK LENGTHS			
1.8	2.1	2.4	3.0 METRES

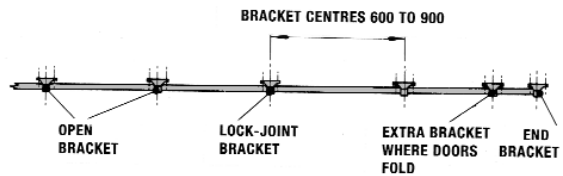

NOTE: THE CENTRE MEETING JOINT DETAIL IS ONLY REQUIRED WHERE SUITES CONTAINING AN EVEN NUMBER OF DOORS MEET WITHIN THE OPENING

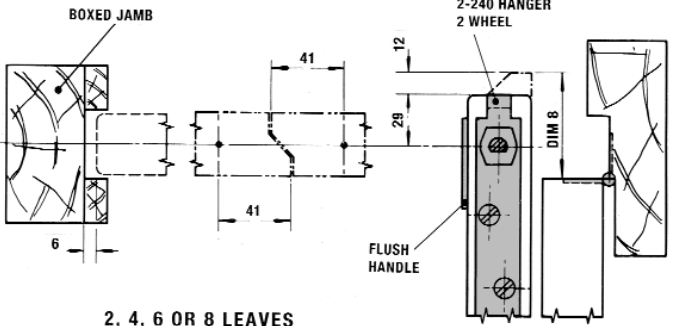
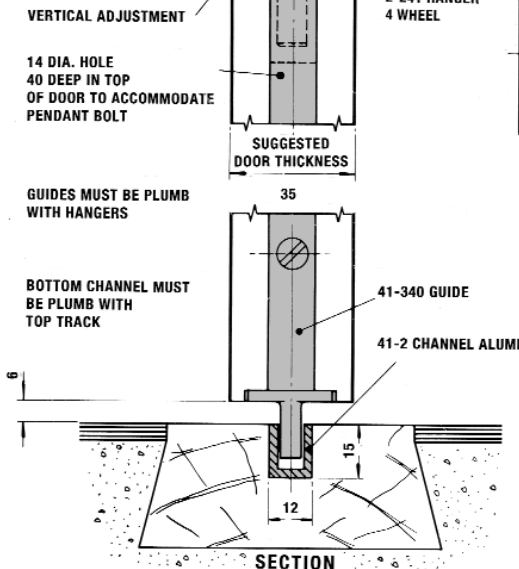

**DIM 'A'**  
29 +  
HALF THICKNESS OF DOOR  
+ OFFSET OF HINGES  
EXAMPLE FOR 35 DOOR  
29 + 18 + 3 = 50

**DIM 'B'**  
29 +  
HALF THICKNESS OF DOOR  
+ OFFSET OF HINGES + 12  
EXAMPLE FOR 35 DOOR  
29 + 18 + 3 + 12 = 62

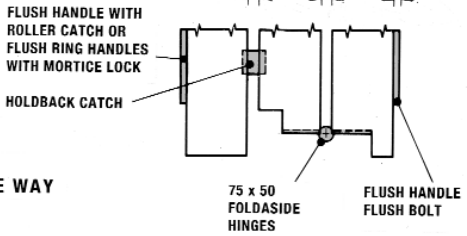
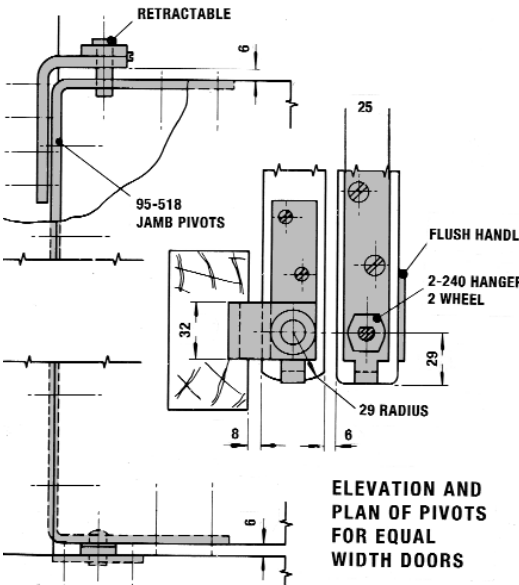
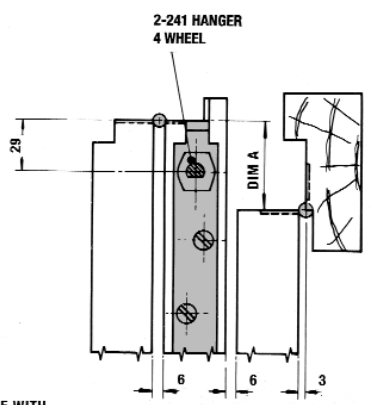

WHEN JAMB PIVOTS ARE REPLACED BY HINGES, PARTICULAR ATTENTION SHOULD BE PAID BY THE JOINER TO LEAF SIZES AND THE USE OF DIMENSION A OR B AS SHOWN

**DOOR ARRANGEMENTS**  
FROM 2 TO 8 LEAVES ONE WAY-  
WITH OR WITHOUT SWING LEAF  
ON OPPOSITE JAMB  
FROM 2 TO 8 LEAVES BOTH WAYS  
FROM 2 TO 8 LEAVED ONE OR BOTH  
WAYS ON PIVOTS

# Foldaside 340 Sliding & Folding Door Systems

## FOR TOP HUNG END FOLDING PARTITIONS

### APPLICATION

Top hung, internal folding doors with concealed fittings. For hospitals, schools, private residence etc

### RANGE

Track size	3-20	3-25
Maximum weight per door leaf	50kg(110lb)	55kg(120lb)
Maximum door height	3.3m(11ft)	3.6m(12ft)
Maximum opening width	14.4m(48ft)	14.4m(48ft)
Maximum door leaf width	900mm(3ft)	900mm(3ft)

Up to 8 leaves may be hinged together. "Loose" or "floating" suites of door leaves are not recommended, alternatively use FOLDASIDE 310, pages 26-27

### DOOR CONSTRUCTION

Door thickness 40 to 55mm. Width of door leaves vary according to arrangements, refer to drawings for details. Rebating to suit hanger aprons is shown. Swing leaves are best hinged to jambs. When hinged to folding suites reduce door widths to 800mm and use four wheel hangers adjoining "swinger". Always engage holdback catch before operating.

### FIXING

Track brackets usually soffit fixed. Additional brackets required where doors park when folded. All hangers have vertical adjustment. Floor channel unnecessary under swing leaves.

### HANGERS

All steel, ball bearing lubricated for life. 3-240 with two wheels. 3-241 with four wheels.

### TRACK

3-20 (2.0mm), 3-25 (2.5mm). Galvanised steel to BS EN 10142. Standard lengths 1.8m to 3.0m.

### TRACK BRACKETS

Steel. See drawing and range on page 3.

### DOOR GUIDES

44-340 Steel angle plate fits rebates of doors. Brass rollers.

### FLOOR CHANNEL

44-1 Galvanised Steel. 44-2 Aluminium. 44-3 Brass. Drilled and countersunk for timber or lugged for concrete. Lengths 1.8m to 3.0m.

### FOLDASIDE BUTT HINGES

95-524 Steel, size 102 x 67. 95-545 Aluminium, anodised with stainless washers and pins, size 102 x 67. All specially drilled.

### FURNITURE

A range of door furniture is shown on page 5.

### FINISHES

Top track galvanised. Aprons and track brackets zinc plated. Furniture usually satin anodised.

### BOLTS AND SCREWS

Included with all fittings except track brackets.

## EXAMPLE

**QUANTITIES FOR A PARTITION 3.6m wide x 2.4m high. Weight of each leaf 38kg. Four leaves folding one way, end leaf hinged to jamb, 5th leaf hinged to opposite jamb.**

### A TYPICAL BILL OF QUANTITIES

ITEM				
A	3-20	Track 1 x 3.0m	3.0	LIN.M
B	3-150	Bracket, open. soffit fixing	6	NO.
C	3-051	Closed End Piece	2	NO.
D		Bolts for brackets (by others)	12	NO.
E	3-240	Hangers, 2 wheel	1	NO.
F	3-241	Hangers, 4 wheel	1	NO.
G	95-545	Foldaside aluminium hinges S.A.A	5	PACKS
H	44-340	Roller guide	2	NO.
J	44-2	Floor channel aluminium d/c/sk 1 x 3.0m		
or J	44-3	Floor channel brass d/c/sk 1 x 3.0m	3.0	LIN.M
K	95-677	Flush bolts S.A.A	2	NO.
L	95-617	Flush handles S.C.	5	NO.
M	95-668	Rebated roller catch	1	NO.

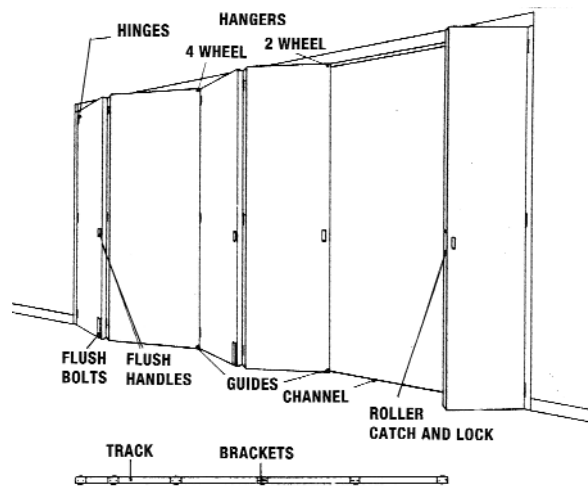

**SPECIAL NOTE:** Particular attention should be paid by the joiner to leaf sizes and the use of Dimension A or B as shown on the opposite page. However, where leaves weigh less than 45kg, a jamb pivot may be used to make this unnecessary.

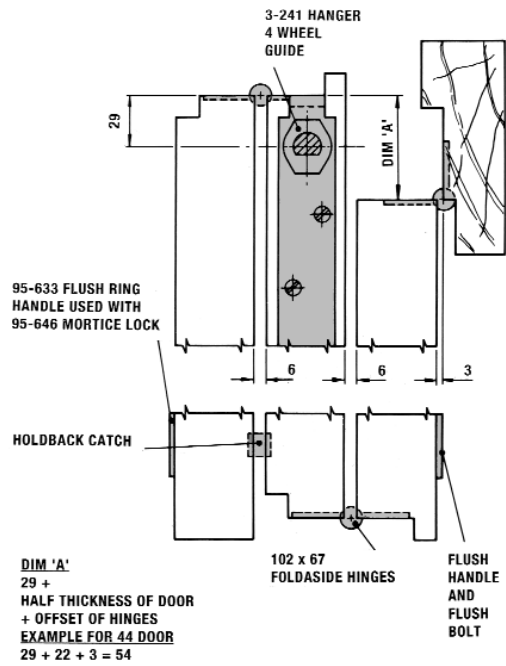
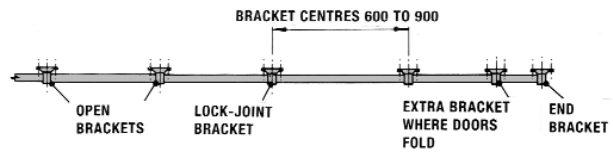
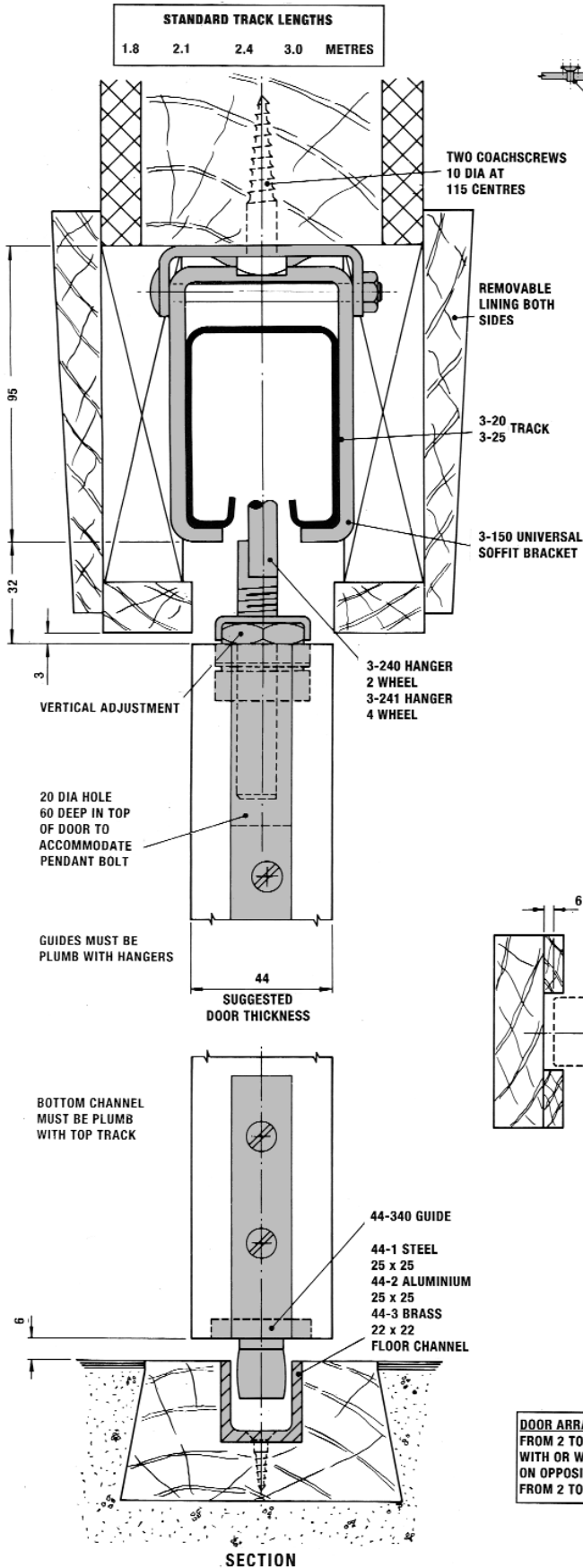

**3, 5 OR 7 LEAVES ONE WAY**

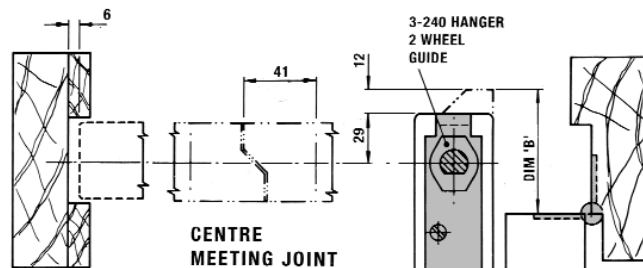

**BOXED JAMB-  
FOR EVEN  
SUITES OF  
DOORS HINGED  
TO JAMB**

**DIM 'B'**  
29 +  
HALF THICKNESS OF DOOR  
+ OFFSET OF HINGES + 12  
EXAMPLE FOR 44 DOOR:-  
29 + 22 + 3 + 12 = 66

**2, 4, 6 OR 8 LEAVES ONE OR BOTH WAYS**

**DOOR ARRANGEMENTS**  
FROM 2 TO 8 LEAVES ONE WAY-  
WITH OR WITHOUT SWING LEAF  
ON OPPOSITE JAMB  
FROM 2 TO 8 LEAVES BOTH WAYS

**NOTE: THE CENTRE MEETING  
JOINT DETAIL IS ONLY REQUIRED  
WHERE SUITES CONTAINING AN  
EVEN NUMBER OF DOORS MEET  
WITHIN THE OPENING**

# Foldaside 640 Sliding & Folding Door Systems

## FOR BOTTOM ROLLING END FOLDING PARTITIONS

### APPLICATION

Bottom rolling, internal folding doors. For openings without rebated head or cills. For hospitals, schools, residences etc.

### RANGE

Maximum door weight	75kg (160lb)
Maximum door height	3.6m (12ft)
Maximum opening width	14.4m (48ft)
Maximum door leaf width	900mm (3ft)

Up to eight leaves may be hinged together. Not suitable for loose suites.

### DOOR CONSTRUCTION

Door thickness 44mm only. Width of door leaves vary according to arrangements, refer to drawing for details. Swing leaves are best hinged to jambs. With swing leaves on folding suites, reduce door height to 3.0m, leaf width to 800mm and weight to 55kg. Always engage holdback catch before operating. As bottom rollers are housed at bottom of stile, keep tenons of rail high to avoid cut-out.

### FIXING

Top track screwed to soffit. Bottom track screwed to accurately machined timber cill to provide complete support to the underside of the running tread without voids, and the cill to be firmly fitted to prevent distortion or deflection. Floor track unnecessary under swing leaves.

### BOTTOM ROLLERS

64-403 Needle bearing rollers, ball bearing swivels, satin anodised aluminium cover plates, (or 64-404 with polished brass cover plates).

### BOTTOM TRACK

64-3 Brass. Drilled and countersunk for wood. Lengths 1.8m to 3.0m.

### TOP TRACK

7-20 (2.0mm) Galvanised steel to BS EN 10142. Drilled and countersunk for wood. Lengths 1.8m to 3.0m.

### TOP GUIDES

7-340 Nylon roller, steel apron fits rebate of door.

### FOLDASIDE BUTT HINGES

95-524 Steel size 102 x 67mm. 95-545 Aluminium, anodised with stainless washers and pins. Size 102 x 67mm. 95-553 Polished Brass 100 x 66mm. All specially drilled.

### FURNITURE

95-677 Flush bolt SAA, 95-670 Flush bolt GAA, 95-617 Flush handle SC, 95-615 Flush handle PB, 95-665 Holdback catch. For range of locks and latches see page 5.

### FINISHES

Bottom roller cover plates, handles and bolts usually SAA or Polished Brass.

### SCREWS

Included with fittings.

**SPECIAL NOTE:** Particular attention should be paid by the joiner to leaf sizes and the reduction of the first leaf at the jamb by 63mm as shown.

## EXAMPLE

**QUANTITIES FOR A DOOR PARTITION 3.9m wide x 3.0m high. Weight of each leaf 60kg. Four leaves folding one way, end leaf hinged to jamb. Fifth hinged to opposite jamb.**

### A TYPICAL BILL OF QUANTITIES

ITEM					
A	7-20	Top track d/c/sk for screws 2 x 1.8m	3.6	LIN.M	
B	7-340	Top guides	2	NO.	
C	95-545	Foldaside aluminium hinges S.A.A.	5	PACKS	
D	64-403	Bottom roller S.A.A. (or 64-404)	2	NO.	
E	64-3	Bottom track, brass, 2 x 1.8m	3.6	LIN.M	
F	95-677	Flush bolt S.A.A.	2	NO.	
G	95-617	Flush handle S.C.	3	NO.	
H	95-633	Flush ring handles satin chrome	2	NO.	
J	95-647	Rebated mortice lock	1	NO.	

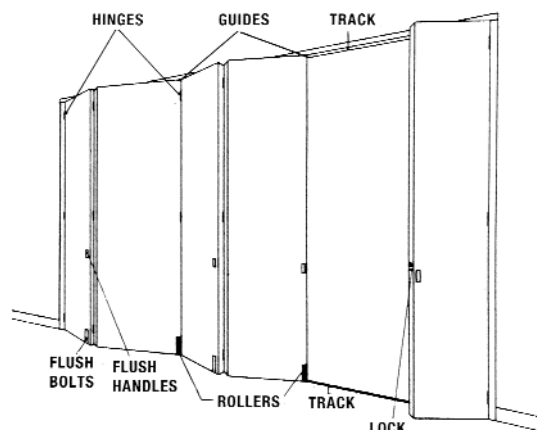





# Foldaside 642 Sliding & Folding Door Systems

## FOR END HUNG BOTTOM ROLLING DOORS FOLDING BACK AGAINST RETURN WALLS

### APPLICATION

Bottom rolling, light duty internal folding doors for residential properties with return walls sufficiently deep to allow doors to fold through 180°.

### RANGE

Maximum door weight	45kg (100lb)
Maximum door height	2.4m (8ft)
Maximum opening width	4.8m (16ft)
Maximum door leaf width	900mm (3ft)

Up to three leaves folding in each direction only.

### DOOR CONSTRUCTION

Door thickness 44mm only. Door leaves are all equal width, but with swing leaves on folding suites reduce door leaf widths to 800mm. As bottom rollers are housed at bottom of stile, keep tenons of rail high to avoid cut-out. With swing leaves always engage holdback catch before operating.

### FIXING

Top track unnecessary, bottom track must be positioned exactly as shown on drawing. Bottom track screwed to accurately machined timber cill to provide complete support to the underside of the running tread without voids, and the cill to be firmly fitted to prevent distortion or deflection. Floor track unnecessary under swing leaves.

### BOTTOM ROLLERS

64-403 Needle bearing rollers, ball bearing swivels. Satin anodised aluminium cover plates, (or 64-404 with polished brass cover plates).

### BOTTOM TRACK

64-3 Brass, drilled and countersunk for wood. Lengths 1.8m to 3.0m.

### FOLDASIDE BUTT HINGES

95-545 Aluminium, anodised with stainless washers and pins, size 102 x 67mm. 95-551 SC size 100 x 100mm. 95-553 PB size 100 x 66mm. All specially drilled.

### FURNITURE

95-677 Plain flush bolt for bottom of door. 95-679 Cranked flush bolt for top of door. 95-617 Flush handle. 95-665 Holdback catch. For range of locks and latches see page 5.

### FINISHES

Bottom roller cover plates in SAA or PB, handles and bolts in SAA or GAA.

### SCREWS

Included with fittings.

## EXAMPLE

QUANTITIES FOR A PARTITION 2.1m wide x 2m high. Weight of each leaf 40kg. Three leaves folding one way through 180°, end leaf hinged to jamb.

### A TYPICAL BILL OF QUANTITIES

ITEM				
A	95-545	Foldaside aluminium hinges S.A.A.	2	PACKS
B	95-551	Foldaside brass hinges S.C.	1	PACK
C	64-403	Bottom roller S.A.A. cover plate (or 64-404 PB)	1	NO.
D	64-3	Bottom track brass d/c/sk 1 x 1.8m	1.8	LIN.M
E	95-665	Holdback catch	1	NO.
F	95-677	Flush bolt, plain S.A.A.	1	NO.
G	95-679	Flush bolt, cranked S.A.A.	1	NO.
H	95-617	Flush handle S.C.	1	NO.
J	95-633	Flush ring handles satin chrome	2	NO.
K	95-646	Mortice lock	1	NO.

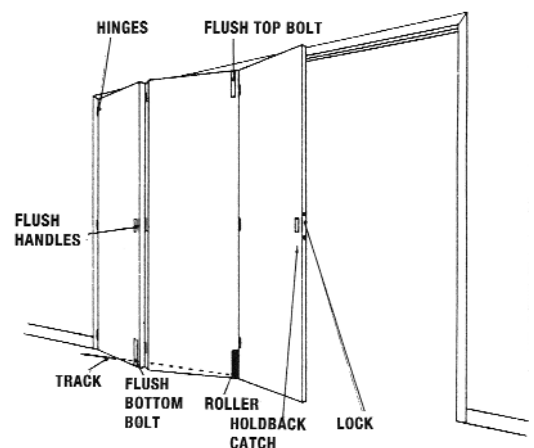



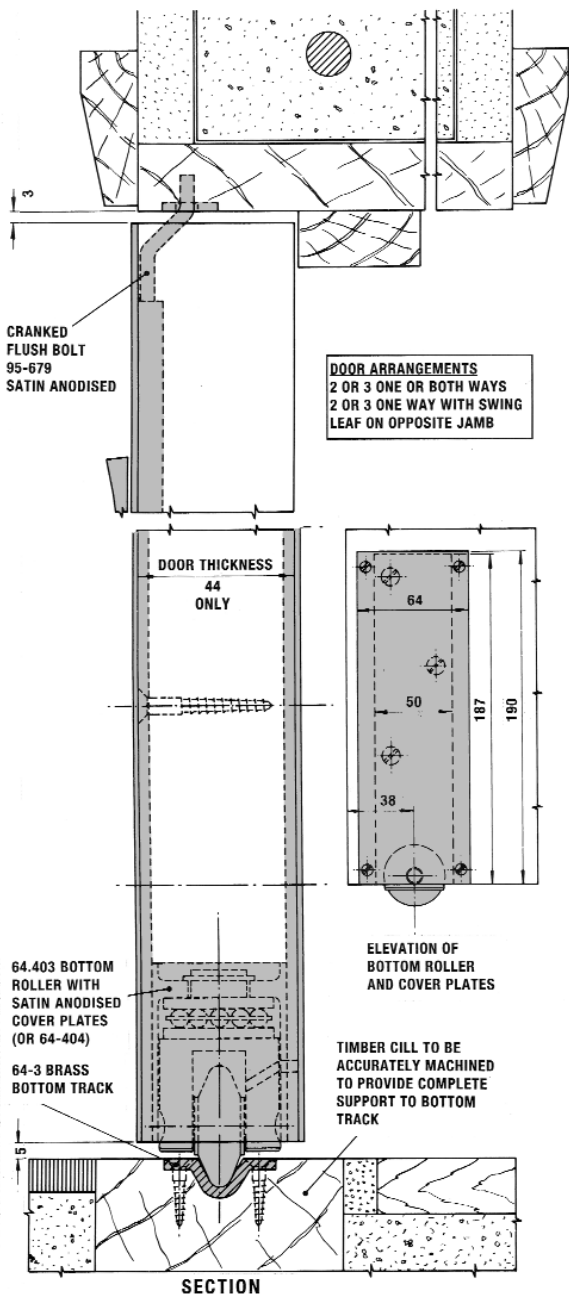

**DOOR ARRANGEMENTS**  
 2 OR 3 ONE OR BOTH WAYS  
 2 OR 3 ONE WAY WITH SWING  
 LEAF ON OPPOSITE JAMB

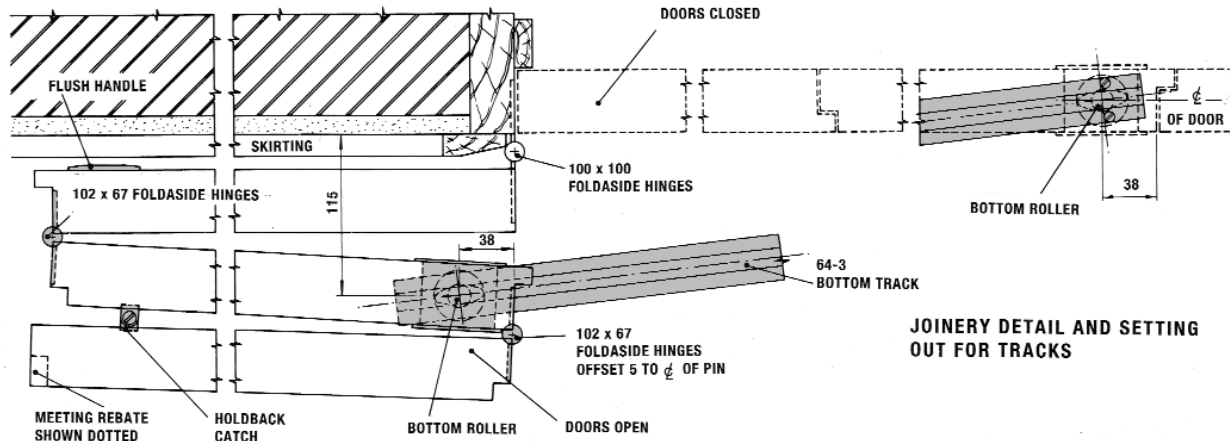
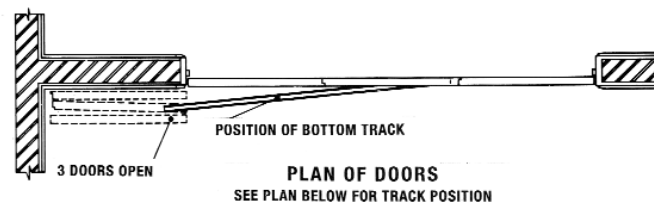
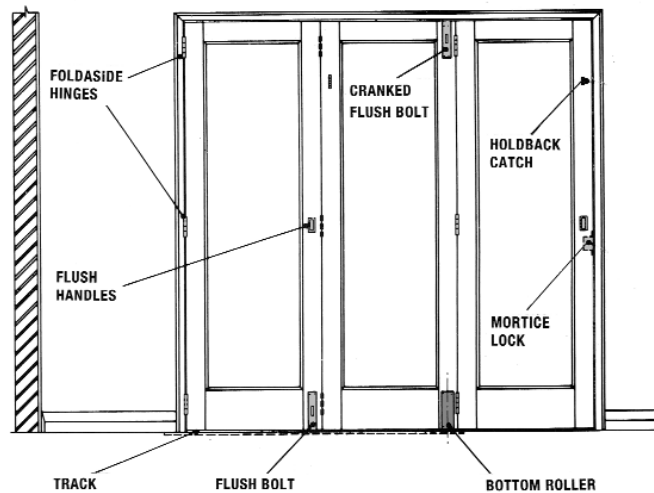
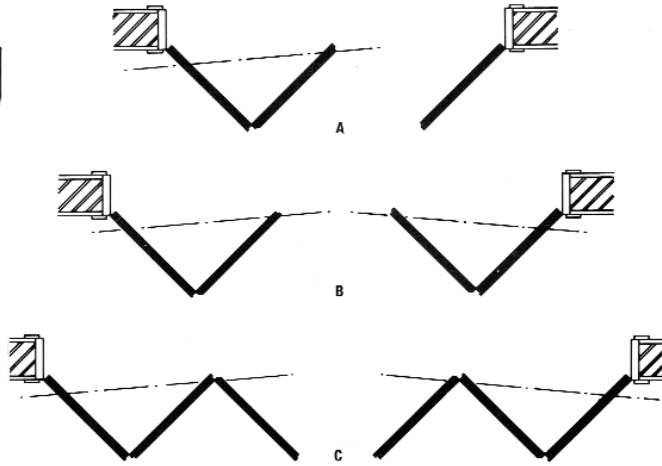

# Centafold 100 Sliding Door Systems

## FOR INTERIOR CENTRE HUNG FOLDING DOORS

### APPLICATION

Top hung, centre folding, light weight interior residential and commercial doors with concealed fixings for hangers and pivots.

### RANGE

Maximum leaf weight 27kg (60lbs)  
 Maximum leaf height 2.5m  
 Maximum leaf width 600mm  
 Leaf thickness between 20 to 40mm. Swing leaves may not be used.

1½ or 3½ leaves may be hinged together with end half leaf pivoted adjacent to jamb. For increased stability, bottom guides and floor channel are recommended on door leaves over 450mm wide. 15kg weight or 2.1m high. Minimum leaf thickness 30mm.

### DOOR CONSTRUCTION

Solid blockboard, louvred or flush panelled construction with adequate provision for fixing end pivots and hangers.

### TRACK

1-12(1.2mm) Galvanised steel to BS EN 10142. Drilled for brackets or soffit fixing. Lengths 1.5m to 3.0m. Extruded aluminium track available as an optional extra.

### TRACK BRACKETS

1-100 Steel, side fixing with two screws.

### HANGERS

1-246 Steel construction. 4 nylon wheels, ball bearings lubricated for life. Vertical adjustment.

### HINGES

95-521 Steel, plated finish. Surface mounted. 3 per joint for doors up to 2.1m high. 4 per joint recommended for higher doors.

### TOP AND BOTTOM PIVOTS

95-508 Pressed steel top housing, clamp fixing in track. Spring loaded pivot fixed to top edge of door. Bottom pivot and housing, pressed steel with nylon socket slide. Vertical and lateral adjustment.

### DOOR GUIDE

41-346 Steel plate, nylon swivel.

### FLOOR CHANNEL

41-2 aluminium. Drilled and countersunk for woodscrew fixing. Lengths 1.5m to 3.0m.

### FURNITURE

A range of furniture is shown on page 5.

### FINISHES

Top track galvanised. Hangers, brackets guides and pivots zinc plated. Furniture usually satin anodised.

## CENTAFOLD DOOR ARRANGEMENTS STANDARD PACKSETS

### TWO DOORS FOLDING - COMPONENT PACK 100-020

For Centafold door arrangements. Comprising; 1 only 1-246 folding door hanger, 1 set top and bottom pivots, 3 only 95-521 hinges, 1 only 95-622 door pull, spanner, installation details and all screws.

### FOUR DOORS FOLDING - COMPONENT PACK 100-040

For Centafold door arrangements. Comprising; 2 only 1-246 folding door hangers, 1 set top and bottom pivots, 9 only 95-521 hinges, 2 only 95-622 door pulls, spanner, installation details and all screws.

### TOP TRACK

Available in the following standard lengths:

1-12-15 length	1.5m	1-12-24 length	2.4m
1-12-18 length	1.8m	1-12-30 length	3.0m
1-12-21 length	2.1m		

### SIDE FIXING TRACK BRACKETS PACKS

1-005 comprising 5 brackets with fixing screws for track lengths 1.5m, 1.8m or 2.1m.

1-008 comprising 8 brackets with fixing screws for track lengths 2.4m or 3.0m.

### BOTTOM GUIDING

41-346 door guides with 41-2 channel in lengths to match top track.

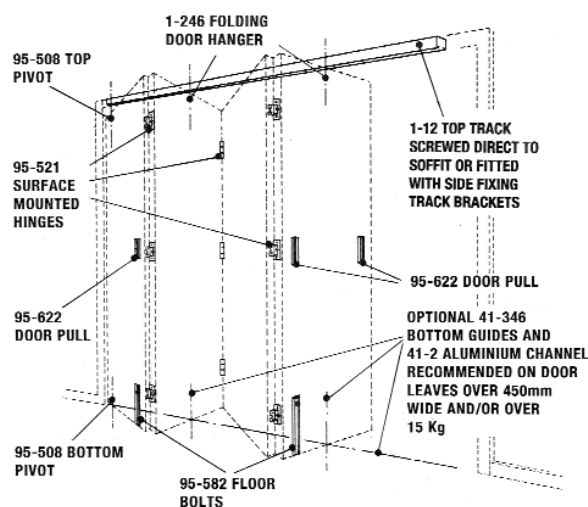

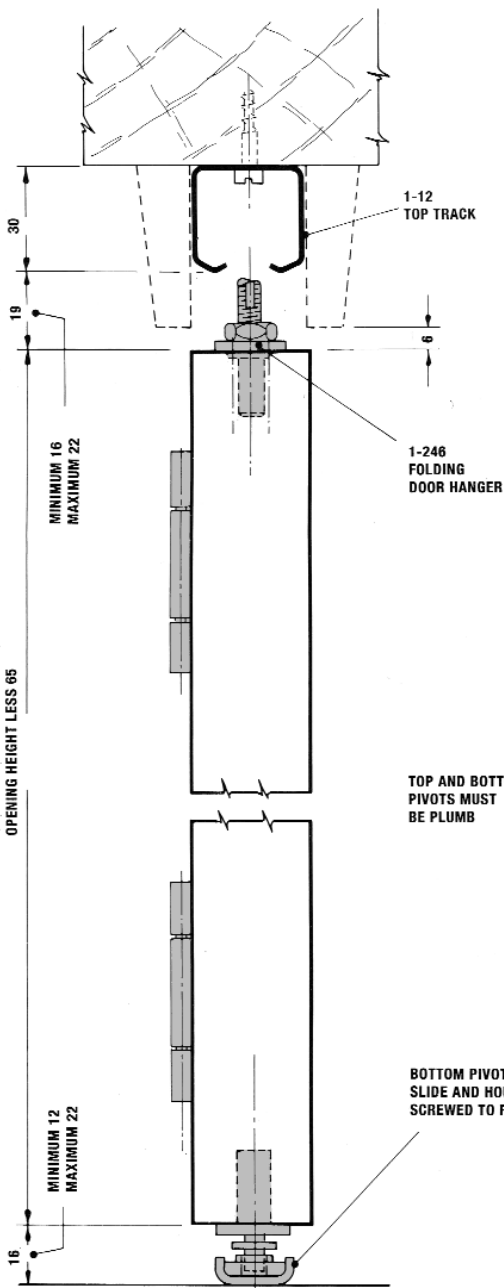

SECTION THROUGH OPENING

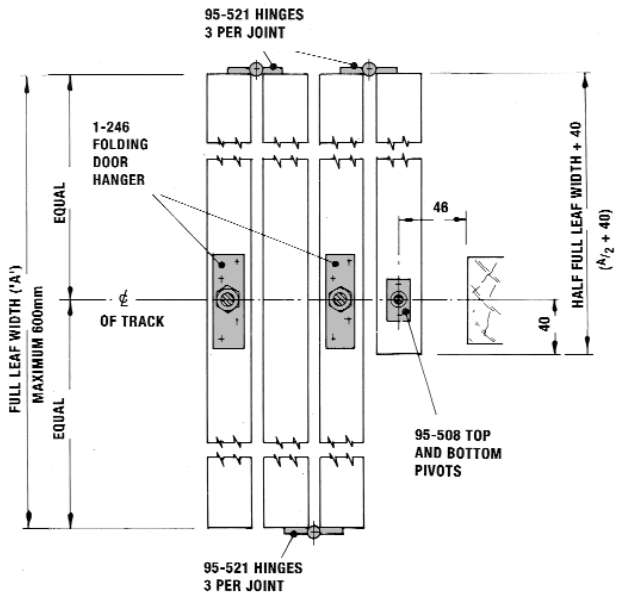

3 1/2 LEAVES FOLDING TO ONE SIDE

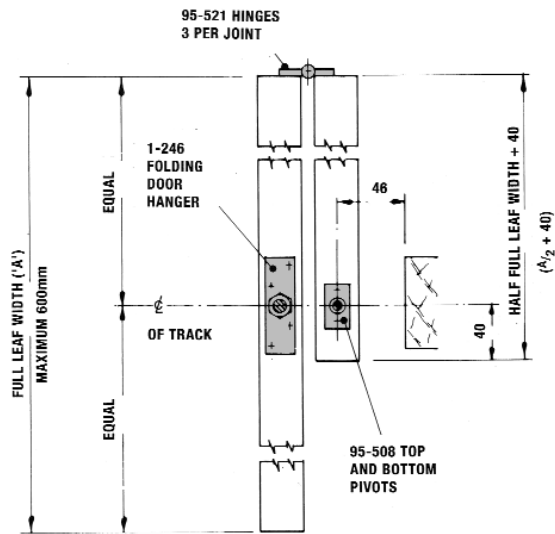

1 1/2 LEAVES FOLDING TO ONE SIDE

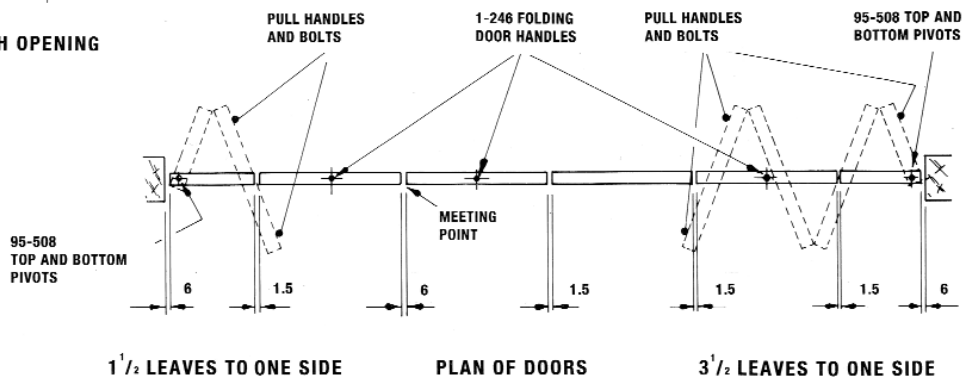

1 1/2 LEAVES TO ONE SIDE

PLAN OF DOORS

3 1/2 LEAVES TO ONE SIDE

# Centafold 250 Sliding & Folding Door Systems

## FOR TOP HUNG CENTRE FOLDING PARTITIONS

### APPLICATION

Top hung, internal folding doors. For openings without rebated heads or cills. For hospitals, schools residences etc.

### RANGE

Maximum door weight	36kg (80lb)
Maximum door height	2.7m (9ft)
Maximum open width	Unlimited
Maximum door leaf width	1.2m (4ft)

Up to 7½ leaves may be hinged together and loose suites of 5 and 7 leaves may be used with care.

### DOOR CONSTRUCTION

Door thickness 35-44mm. Width of door leaves vary according to arrangements, refer to drawings for details. The half leaf is always hinged to jamb. With swing leaves on folding suites, reduce door leaf widths to 700mm. Always engage holdback catch before operating.

### FIXING

Track brackets usually soffit fixed. Universal soffit bracket designed for ease of fixing and versatility. Additional brackets required where doors park when folded. All hangers have vertical adjustment. Floor channel unnecessary under swing leaves.

### HANGERS

All steel, ball bearing, lubricated for life. 2-245 with two wheels. 2-246 with four wheels.

### TRACK

2-16 (1.6mm) Galvanised steel to BS EN 10142. Standard length 1.8m to 3.0m.

### TRACK BRACKETS

Steel. See drawing and range on page 3.

### DOOR GUIDES

41-345 Steel plate, nylon swivel.

### FLOOR CHANNEL

41-2 Aluminium. Drilled and countersunk for timber. Lengths 1.8m to 3.0m.

### FOLDASIDE BUTT HINGES

95-520 Steel size 75 x 50mm. 95- 541 Aluminium, anodised with stainless washers and pins, size 75 x 50mm. All specially drilled.

### FURNITURE

A range of door furniture is shown on page 5.

### FINISHES

Track galvanised. Hanger plates and brackets zinc plated. Furniture usually satin anodised.

### BOLTS AND SCREWS

Included with all fittings except track brackets.

**SPECIAL NOTE:** Particular attention should be paid by the joiner to leaf sizes and the use of dimension A as shown on the opposite page.

## EXAMPLE

**QUANTITIES FOR A PARTITION 3.8m wide x 2.4m high. Weight of each leaf 30kg, Four-and-a-half leaves folding one way, half leaf hinged to a jamb.**

### A TYPICAL BILL OF QUANTITIES

ITEM				
A	2-16	Track 2 x 1.8m	3.6	LIN.M
B	2-150	Bracket, open, soffit fixing	5	NO.
C	2-051	Closed End Piece	1	PACK
D	2-152	Bracket, lock-joint, soffit fixing	1	NO.
E		Bolts for brackets (by others)	12	NO.
F	2-245	Hangers two wheel	1	NO.
G	2-246	Hangers four wheel	1	NO.
H	95-541	Foldaside aluminium hinges S.A.A.	5	PACKS
J	41-345	Bottom guide	2	NO.
K	41-2	Floor channel aluminium d/c/sk 2 x 1.8m	3.6	LIN M
L	95-675	Flush bolt S.A.A.	3	NO.
M	95-617	Flush handle S.C.	3	NO.

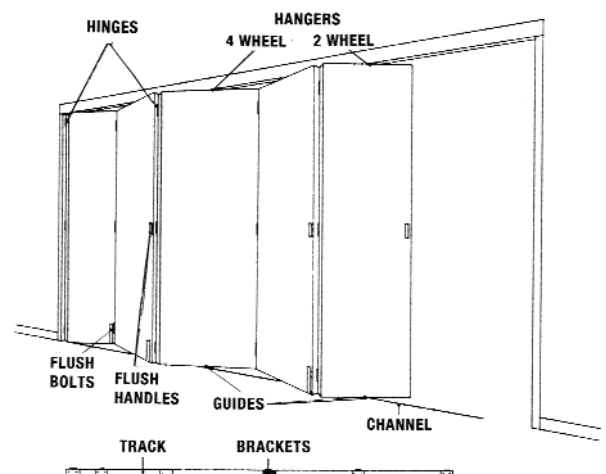

STANDARD TRACK LENGTHS				
1.8	2.1	2.4	3.0	METRES

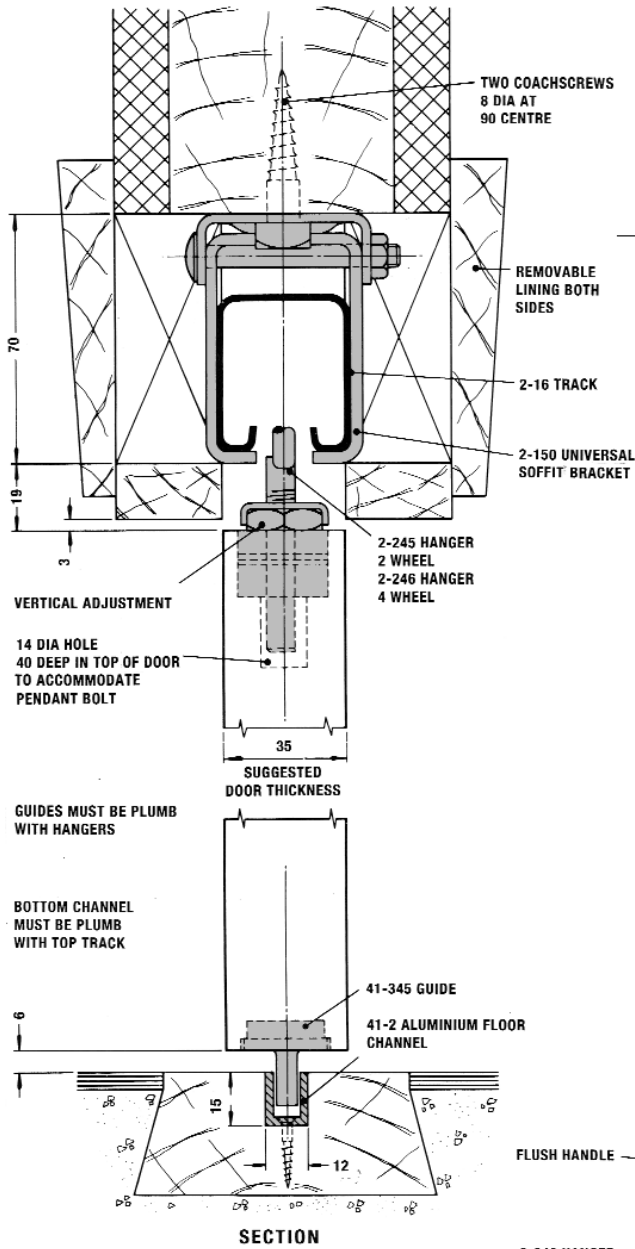

**DOOR ARRANGEMENTS**  
 FROM 1 1/2 TO 7 1/2 LEAVES ONE OR BOTH WAYS-WITH OR WITHOUT SWING LEAVES ON SUITES OR OPPOSITE JAMB  
 5 OR 7 LEAVES 'FLOATING'

**DIM 'A'**  
 HALF THICKNESS OF DOOR + OFFSET OF HINGES  
 EXAMPLE FOR 35 DOOR:-  
 18 + 3 = 21

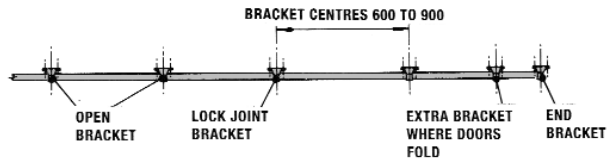

ARRANGE BI-PARTING DOORS SO THAT REBATES SWING INTO EACH OTHER THIS IS CONTROLLED BY HINGING HALF LEAF RIGHT OR LEFT AS REQUIRED

WHEN USING SWING DOORS ENGAGE HOLDBACK CATCH BEFORE OPERATING PARTITION

1 1/2, 3 1/2, 5 1/2, 7 1/2  
**LEAVES WITHOUT SWING DOOR**  
 OR 2 1/2, 4 1/2, 6 1/2  
**LEAVES INCLUDING SWING DOOR**

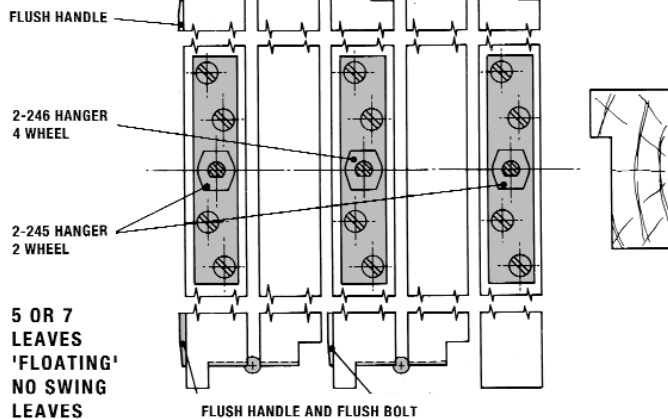
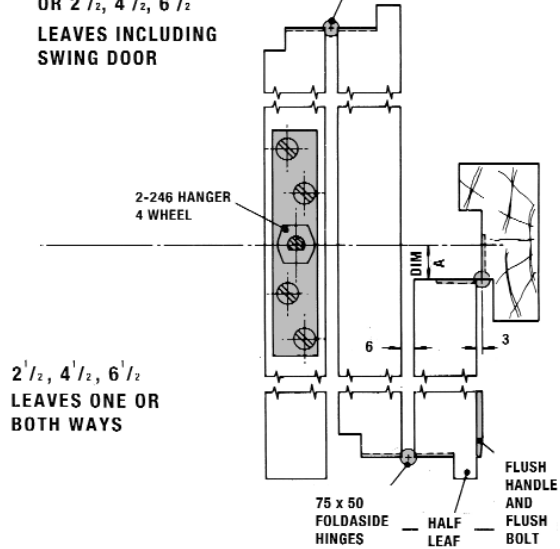
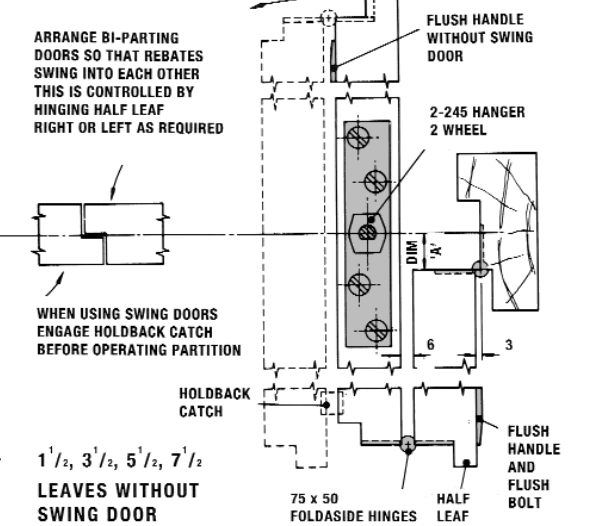



# Centafold 350 Sliding & Folding Door Systems

## FOR TOP HUNG CENTRE FOLDING PARTITIONS

### APPLICATION

Top hung, light duty, internal folding doors. For openings without rebated heads or cills. For residential application, etc.

### RANGE

Track	3-20	3-25
Maximum door weight	60kg(130lb)	65kg(140lb)
Maximum door height	3.3m(11ft)	3.6m(12ft)
Maximum opening width	Unlimited	Unlimited
Maximum door leaf width	1.2m(4ft)	1.2m(4ft)

Up to 7½ leaves may be hinged together and loose suites of 5 and 7 leaves may be used with care.

### DOOR CONSTRUCTION

Door thickness 44 to 55mm. Width of door leaves vary according to arrangements, refer to drawing for details. The half leaf is always hinged to jamb. With swing leaves on folding suites reduce door leaf widths to 800mm. Always engage holdback catch before operating.

### FIXING

Track brackets usually soffit fixed. Universal soffit bracket designed for ease of fixing and versatility, additional brackets required where doors park when folded. All hangers have vertical adjustment. Floor channel unnecessary under swing leaves.

### HANGERS

All steel, ball bearing, lubricated for life 3-245 with two wheels. 3-246 with four wheels.

### TRACK

3-20 (2.0mm). 3-25 (2.5mm). Galvanised steel to BS EN 10142. Standard lengths 1.8m to 3.0m.

### TRACK BRACKETS

Steel. See drawing and range on page 3.

### DOOR GUIDES

44-345 Steel plate, brass roller.

### FLOOR CHANNEL

44-1 Galvanised Steel. 44-2 Aluminium. 44-3 Brass. Drilled and countersunk for timber. Lengths 1.8m to 3.0m.

### FOLDASIDE BUTT HINGES

95-524 Steel, size 102 x 67. 95-545 Aluminium, anodised with stainless washers and pins, size 102 x 67. All specially drilled.

### FURNITURE

A range of door furniture is shown on page 5.

### FINISHES

Top track galvanised. Aprons and brackets zinc plated. Furniture usually satin anodised.

### BOLTS AND SCREWS

Included with all fittings except track brackets.

## EXAMPLE

**QUANTITIES FOR A PARTITION 4.3mm wide x 2.9m high. Weight of each leaf 50kg. Five-and-a-half leaves folding one way, half section hinged to jamb.**

### A TYPICAL BILL OF QUANTITIES

ITEM				
A	3-20	Track 1 x 2.4m, 1 x 1.8m	4.2	LIN.M
B	3-150	Bracket, open, soffit fixing	6	NO.
C	3-051	Closed End Piece	2	NO.
D	3-152	Bracket, lock-joint, soffit fixing	1	NO.
E		Bolts for brackets (by others)	14	NO.
F	3-245	Hangers two wheel	2	NO.
G	3-246	Hangers four wheel	1	NO.
H	95-545	Foldaside aluminium hinges S.A.A.	6	PACKS
J	44-345	Bottom guide	3	NO.
K	44-2	Floor channel aluminium d/c/sk 1 x 2.4m, 1 x 1.8m	4.2	LIN.M
or K	44-3	Floor channel brass d/c/sk 1 x 2.4m, 1 x 1.8m	4.2	LIN.M
L	95-677	Flush bolt S.A.A.	3	NO.
M	95-617	Flush handle S.C.	3	NO.

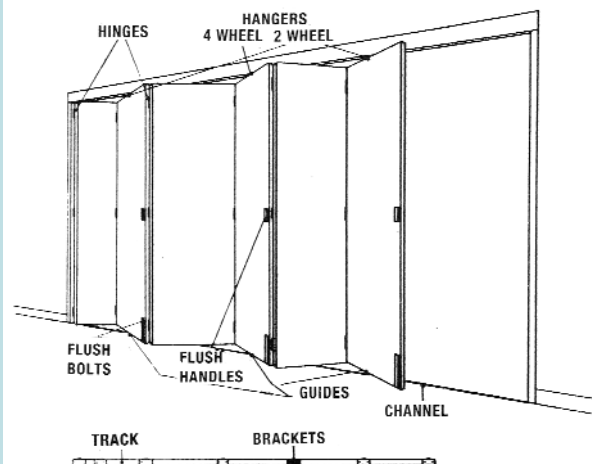



STANDARD TRACK LENGTHS				
1.8	2.1	2.4	3.0	METERS

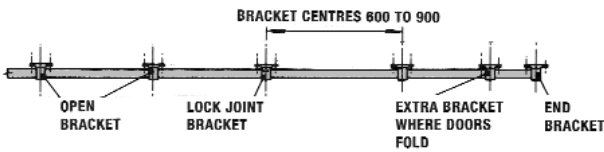
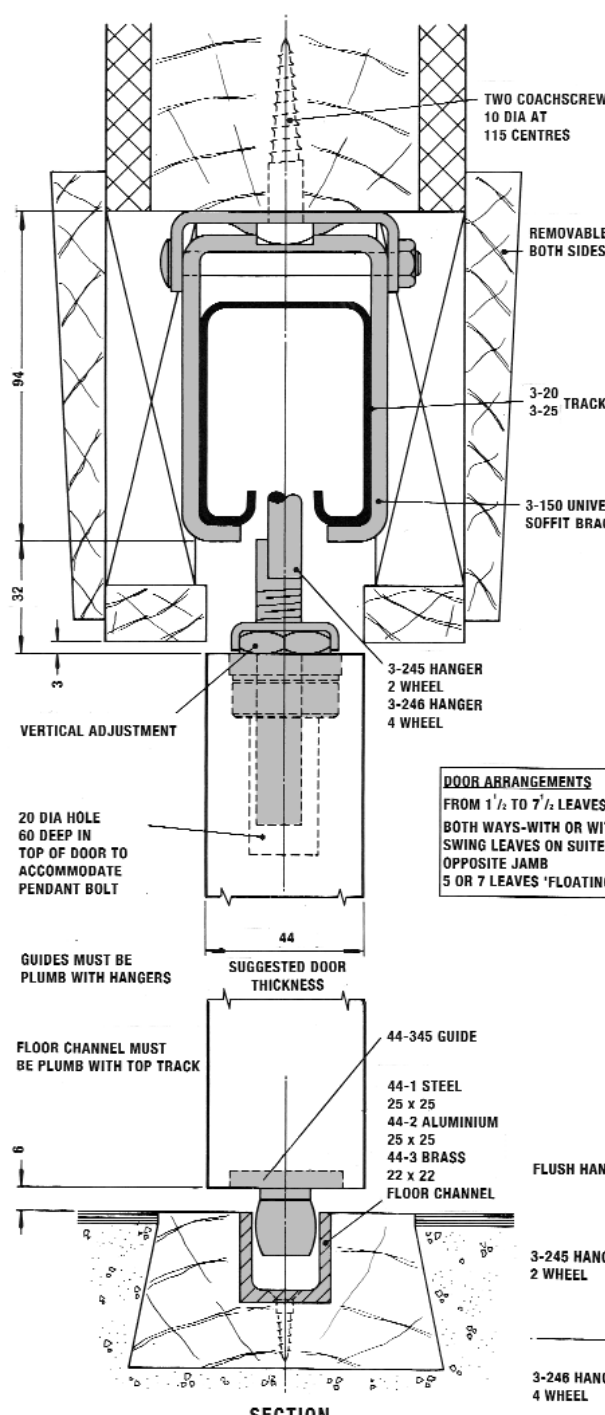

ARRANGE BI-PARTING DOORS SO THAT REBATES SWING INTO EACH OTHER THIS IS CONTROLLED BY HINGING HALF LEAF RIGHT OR LEFT AS REQUIRED

WHEN USING SWING DOORS ENGAGE HOLDBACK CATCH BEFORE OPERATING PARTITION

1 1/2, 3 1/2, 5 1/2, 7 1/2, LEAVES WITHOUT SWING DOOR OR 2 1/2, 4 1/2, 6 1/2 LEAVES INCLUDING SWING DOOR

2 1/2, 4 1/2, 6 1/2 LEAVES ONE OR BOTH WAYS

5 OR 7 LEAVES 'FLOATING' NO SWING LEAVES

**DOOR ARRANGEMENTS**  
FROM 1 1/2 TO 7 1/2 LEAVES ONE OR BOTH WAYS-WITH OR WITHOUT SWING LEAVES ON SUITES OR OPPOSITE JAMB  
5 OR 7 LEAVES 'FLOATING'

- 44-1 STEEL 25 x 25
- 44-2 ALUMINIUM 25 x 25
- 44-3 BRASS 22 x 22
- FLOOR CHANNEL

**DIM 'A'**  
HALF THICKNESS OF DOOR + OFFSET OF HINGES  
EXAMPLE FOR 44 DOOR:-  
22 + 3 = 25

SWING LEAVES MUST NOT BE HINGED TO FLOATING SUITES

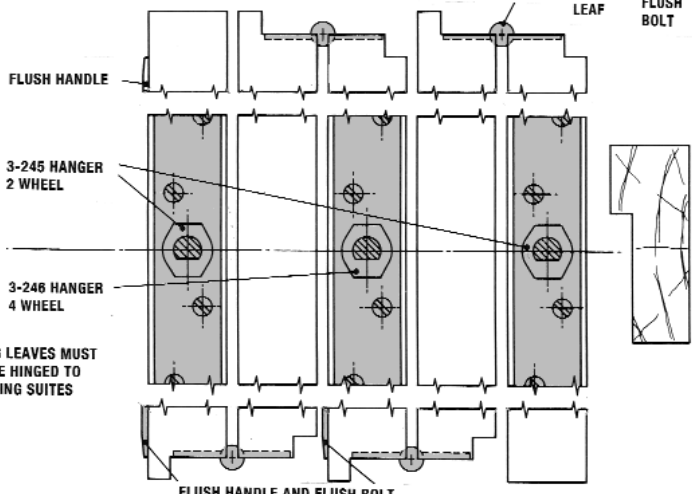
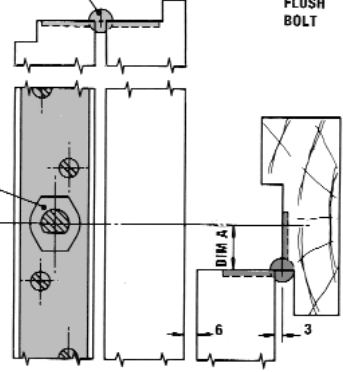
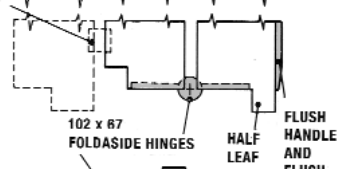
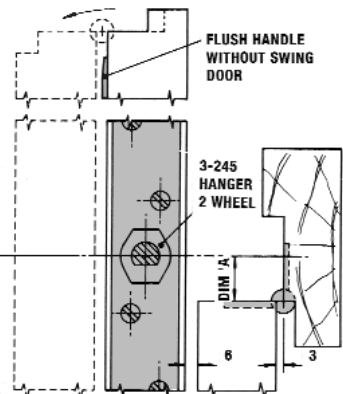

# Centafold 644 Sliding & Folding Door Systems

## FOR BOTTOM ROLLING CENTRE FOLDING PARTITIONS

### APPLICATION

Bottom rolling internal folding doors. For openings without rebated heads or cills. For hospitals, schools, residences etc.

### RANGE

Maximum door weight	60kg	(1301b)
Maximum door height	3.6m	(12ft)
Maximum open width	18m	(59ft)
Maximum door leaf width	1.2m	(4ft)

Up to 7½ leaves may be hinged together.

### DOOR CONSTRUCTION

Door thickness 44mm only. Width of door leaves vary according to arrangements, refer to drawing for details. The half leaf is always hinged to jamb. With swing leaves on folding suites reduce door height to 3.0m, leaf width to 800mm and weight to 45kg. Always engage holdback catch before operating.

### FIXING

Top track screwed to soffit. Bottom track screwed to accurately machined timber cill to provide complete support to the underside of the running tread without voids, and the cill be firmly fitted to prevent distortion or deflection. Floor track unnecessary under swing leaves.

### BOTTOM ROLLERS

64-405 Needles bearing rollers, ball bearing swivels. Satin anodised aluminium cover plates, (or 64-406 with polished brass cover plates).

### BOTTOM TRACK

64-3 Brass. Drilled and countersunk for wood. Lengths 1.8m to 3.0m.

### TOP TRACK

7-20 (2.0m) Galvanised steel to BS EN 10142. Drilled and countersunk for wood. Lengths 1.8m to 3.0m.

### TOP GUIDES

7-345 Nylon roller, steel plate.

### FOLDASIDE BUTT HINGES

95-524 Steel, size 102 x 67. 95-545 SAA size 102 x 67mm. 95-553 PB size 100 x 66mm. All specially drilled.

### FURNITURE

95-677 Flush bolt SAA, 95-670 Flush bolt GAA. 95-617 Flush handle SC, 95-615 Flush handle PB, 95-665 Holdback catch. For range of locks and latches see page 5.

### FINISHES

Top track galvanised. Bottom roller cover plates in SAA or PB, handles and bolts in SAA or GAA.

### SCREWS

Included with all fittings

**SPECIAL NOTE:** Particular attention should be paid by the joiner to leaf sizes and the reduction of the first leaf at the jamb by 25mm as shown on the opposite page.

## EXAMPLE

**QUANTITIES FOR A DOOR PARTITION 3.8m wide x 2.7m high. Weight of each leaf 50kg. Four-and-a-half leaves folding one way, half section hinged to a jamb.**

### A TYPICAL BILL OF QUANTITIES

ITEM				
A	7-20	Top track d/c/sk. 2 x 1.8m	3.6	LIN.M
B	7-345	Top guides	2	NO.
C	95-545	Foldaside aluminium hinges S.A.A.	5	PACKS
D	64-405	Bottom roller S.A.A. (or 64-406 PB)	2	NO.
E	64-3	Bottom track brass 2 x 1.8m	3.6	LIN.M
F	95-677	Flush bolt S.A.A.	2	NO.
G	95-617	Flush handle S.C.	3	NO.

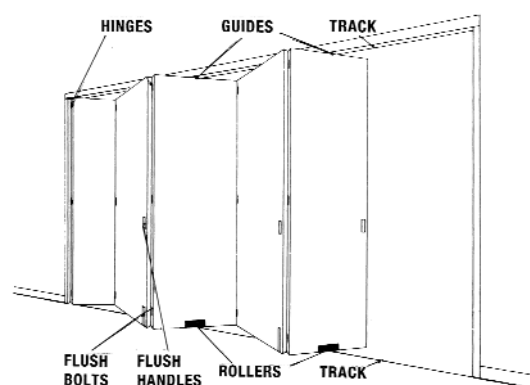

STANDARD TRACK LENGTHS				
1.8	2.1	2.4	3.0	METRES

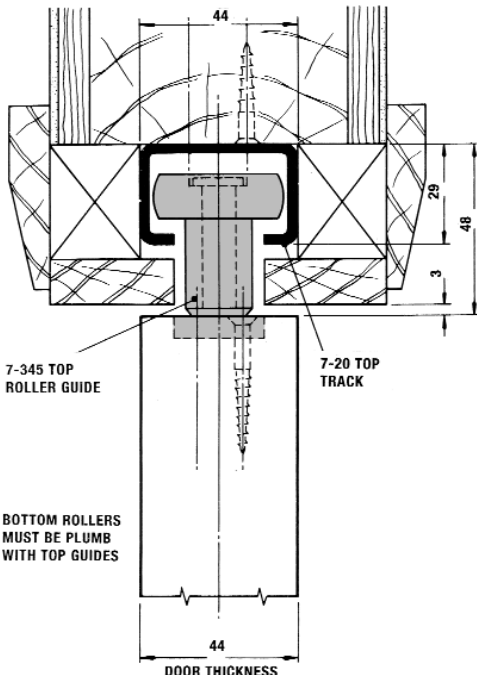

BOTTOM ROLLERS MUST BE PLUMB WITH TOP GUIDES

BOTTOM TRACK MUST BE PLUMB WITH TOP TRACK

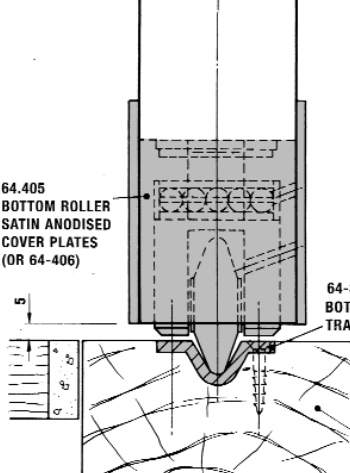

SECTION-TIMBER FLOOR

ARRANGE BI-PARTING DOORS SO THAT REBATES SWING INTO EACH OTHER. THIS IS CONTROLLED BY HINGING HALF LEAF RIGHT OR LEFT AS REQUIRED



MEETING JOINT

WHEN USING SWING DOORS ENGAGE HOLDBACK CATCH BEFORE OPERATING PARTITION

4 1/2 LEAVES ONE-OR BOTH-WAYS

TIMBER CILL TO BE ACCURATELY MACHINED TO PROVIDE COMPLETE SUPPORT TO BOTTOM TRACK

2 1/2 LEAVES ONE-OR BOTH-WAYS

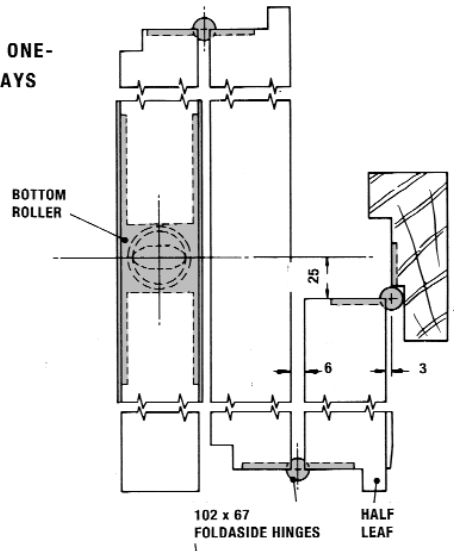

BOTTOM ROLLER

102 x 67 FOLDASIDE HINGES

HALF LEAF

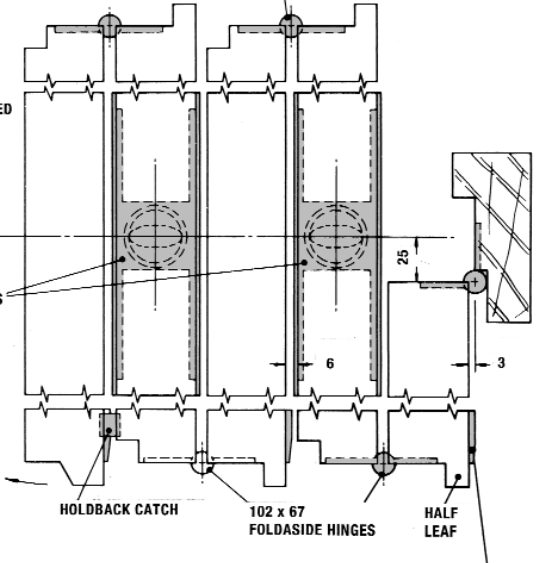

BOTTOM ROLLERS

HOLDBACK CATCH

102 x 67 FOLDASIDE HINGES

HALF LEAF

FLUSH HANDLE AND FLUSH BOLT

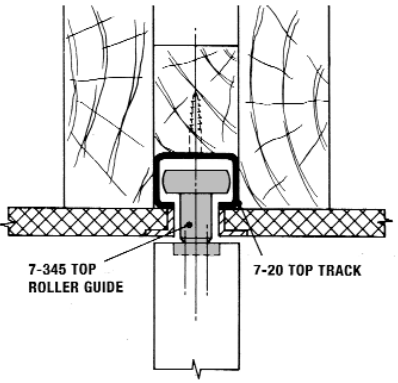

TOP TRACK IN CEILING

**DOOR ARRANGEMENTS**  
 FROM 1 1/2 TO 7 1/2 LEAVES ONE OR BOTH WAYS-WITH OR WITHOUT SWING LEAVES ON SUITES OR OPPOSITE JAMB  
 FROM 1 1/2 TO 7 1/2 LEAVES BOTH WAYS-WITH OR WITHOUT SWING LEAF ON SUITES

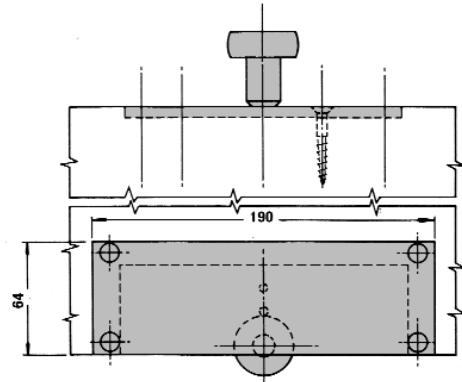

ELEVATION OF TOP GUIDE AND BOTTOM ROLLER

# Foldaside 210 Sliding & Folding Door Systems

## FOR TOP HUNG FOLDING DOORS

### APPLICATION

Top hung internal folding doors with backflap fittings. Suitable for folding behind return walls and into rebated head. For hospitals, schools, offices etc.

### RANGE

Maximum weight per door leaf	36kg (80lb)
Maximum door height	2.4m (8ft)
Maximum opening width	Unlimited
Maximum door leaf width	800m (2ft 8ins)

Up to 8 leaves may be hinged together in loose suites or hinged to jambs.

### DOOR CONSTRUCTION

Door thickness 32 to 44mm. Width of door leaves vary according to arrangements, refer to drawings for details. Swing leaves are best hinged to jambs. When hinged to folding suites, reduce door leaf widths to 700mm. Always engage holdback catch before operating.

### FIXING

Side fixing standard. Additional brackets required where doors park when folded. Hangers and guides have vertical adjustment. Channel unnecessary under swing leaves.

### HANGERS

Steel, ball bearing, lubricated for life. Pressed steel backflaps. 2-217 End pattern. 2-221 Centre pattern.

### TRACK

2-16 (1.6mm). Galvanised steel to BS EN 10142. Standard lengths 1.8m to 3.0m.

### TRACK BRACKETS

See drawing and range on page 3.

### FOLDASIDE BUTT HINGES

Steel, 95-520 size 75 x 50mm and 95-526 size 100 x 75mm. Aluminium, 95-541 size 75 x 50mm and 95-547 size 100 x 75mm. Aluminium hinges provided with stainless steel washers and pins. All specially drilled.

### DOOR GUIDES

Brass rollers. Pressed steel backflaps. 44-317 End pattern 44-321 Centre pattern.

### FLOOR CHANNEL

44-1 Galvanised Steel. 44-2 Aluminium. 44-3 Brass. Drilled and countersunk for wood or lugs for concrete. Lengths 1.8m to 3.0m.

### FURNITURE

A range of furniture is shown on page 5

### FINISHES

Top track galvanised, brackets and backflaps zinc plated. Furniture satin anodised.

### BOLTS AND SCREWS

Included with all fittings except track brackets.

## EXAMPLE

**QUANTITIES FOR A PARTITION 3.0m wide x 2.4m high. Weight of each leaf 34kg. Four leaves folding one way, end leaf hinged to jamb.**

### A TYPICAL BILL OF QUANTITIES

ITEM				
A	2-16	Track 1 x 3.0m	3.0	LIN M
B	2-100	Brackets, open, side wall fixing	6	NO.
C	2-051	Closed End Piece	1	PACK
D	2-217	Hanger end pattern	1	NO.
E	2-221	Hanger centre pattern	1	NO.
F	95-541	Foldaside aluminium hinges S.A.A.	2	PACKS
G	95-547	Foldaside aluminium hinges S.A.A	2	PACKS
H	44-317	Bottom guide end pattern	1	NO.
I	44-321	Bottom guide centre pattern	1	NO.
J	44-2	Floor channel, aluminium 1 x 3.0m	3.0	LIN.M
or K	44-3	Floor channel, brass 1 x 3.0m	3.0	LIN.M
L	95-677	Flush bolt S.A.A.	2	NO.
M	95-617	Flush handle S.C.	3	NO.

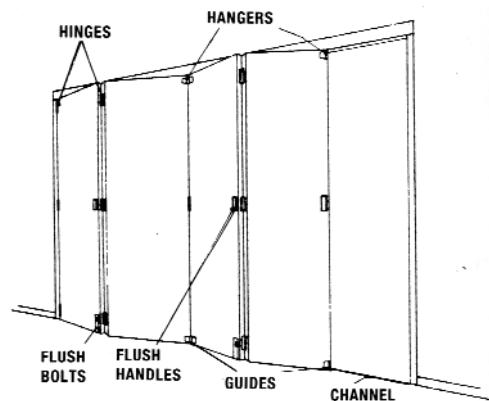

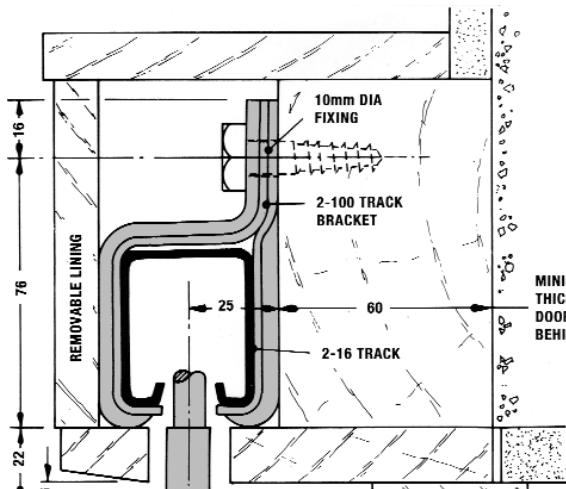

SECTION THROUGH OPENING

STANDARD TRACK LENGTHS				
1.8	2.1	2.4	3.0	METRES

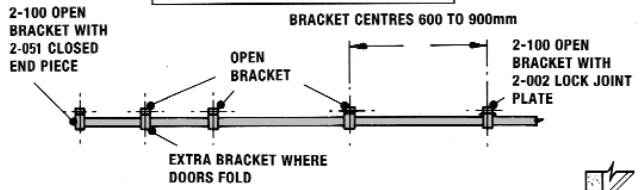

MINIMUM THICKNESS FOR DOORS FOLDING BEHIND RETURN

2-221 CENTRE HANGER- 95-526 STEEL OR 95-547 S.A.A. HINGES 100 x 75mm 44-321 GUIDE

95-617 FLUSH HANDLE AND 95-665 HOLDBACK CATCH  
IF THIS LEAF FOLDS TO JAMB OMIT REBATE

95-526 STEEL OR 95-547 S.A.A. HINGES 100 x 75mm

95-520 STEEL OR 95-541 S.A.A. HINGES 75 x 50mm (SEE NOTE BELOW)

95-677 FLUSH BOLTS AND 95-617 FLUSH HANDLES

3, 5 OR 7 LEAVES ONE OR BOTH WAYS

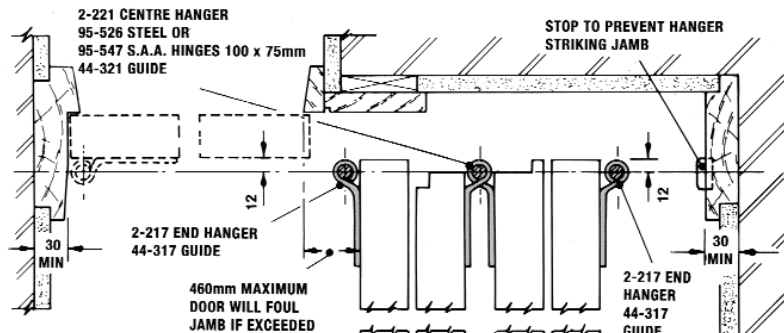

**DOOR ARRANGEMENTS**  
FROM 2 TO 8 LEAVES ONE WAY WITH OR WITHOUT SWING LEAF ON OPPOSITE JAMB  
FROM 2 TO 8 LEAVES BOTH WAYS  
4, 6 OR 8 LEAVES 'FLOATING'

95-520 STEEL OR 95-541 S.A.A. HINGES 75 x 50mm (USE 89 x 60mm HINGES ON DOORS 44mm THICK)

4, 6 OR 8 LEAVES FLOATING ONE WAY

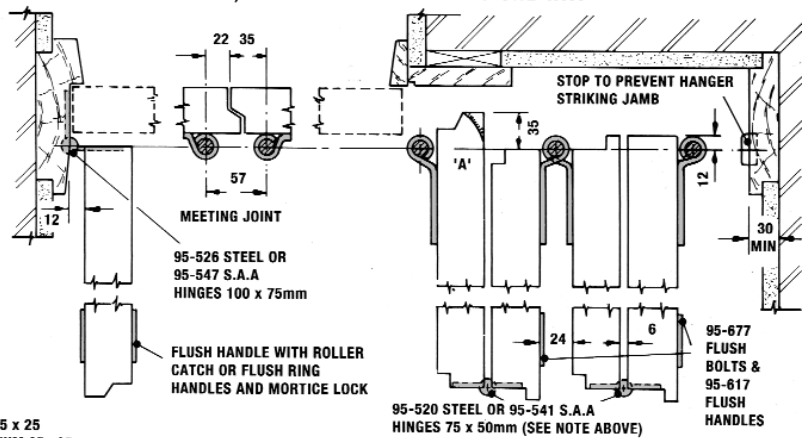

4, 6 OR 8 LEAVES FLOATING ONE WAY WITH SWING LEAF ON OPPOSITE JAMB



# Foldaside 310 Sliding & Folding Door Systems

## FOR TOP HUNG FOLDING DOORS

### APPLICATION

Top hung internal folding doors with backflap fittings. Suitable for folding behind return walls and into rebated head. For hospitals, schools, offices etc.

### RANGE

Track size	3-20	3-25
Maximum weight per door leaf	50kg(110lb)	55kg(120lb)
Maximum door height	3.3m(11ft)	3.6m(12ft)
Maximum opening width	Unlimited	Unlimited
Maximum door leaf width	900mm(3ft)	900mm(3ft)

Up to 8 leaves may be hinged together in loose suites or hinged to jambs.

### DOOR CONSTRUCTION

Door thickness 44 to 55mm. Width of door leaves vary according to arrangements, refer to drawings for details. Swing leaves are best hinged to jambs. When hinged to folding suites reduce door leaf widths to 800mm. Always engage holdback catch before operating.

### FIXING

Side fixing standard. Additional brackets required where doors park when folded. Hangers and guides have vertical adjustment. Channel unnecessary under swing leaves.

### HANGERS

Steel, ball bearing, lubricated for life. Pressed steel backflaps 3-217 End pattern. 3-221 Centre pattern.

### TRACK

3-20 (2.0mm), 3-25 (2.5mm). Galvanised steel to BS EN 10142. Standard lengths 1.8m to 6.0m.

### TRACK BRACKETS

See drawing and range on page 3.

### FOLDASIDE BUTT HINGES

Steel, 95-524 size 102 x 67, 95-526 size 100 x 75 and 95-530 size 100 x 100. Aluminium anodised with stainless washers and pins. 95-545 size 102 x 67 and 95-547 size 100 x 75. Brass, 95-551 size 100 x 100. Satin chrome. All specially drilled.

### DOOR GUIDES

Brass rollers. Pressed steel backflaps 44-317 End pattern. 44-321 Centre pattern.

### FLOOR CHANNEL

44-1 Galvanised Steel. 44-2 Aluminium, 44-3 Brass. Drilled and countersunk for wood or lugs for concrete. Lengths 1.8m to 3.0m.

### FURNITURE

A range of furniture is shown on page 5.

### FINISHES

Top track galvanised, brackets and backflaps zinc plated. Furniture satin anodised.

### BOLTS AND SCREWS

Included with all fittings except track brackets.

## EXAMPLE

**QUANTITIES FOR A PARTITION 3.6m wide x 3.3m high. Weight at each leaf 48kg. Four leaves folding one way, end leaf hinged to jamb.**

### A TYPICAL BILL OF QUANTITIES

ITEM				
A	3-20	Track 2 x 1.8m	3.6	LIN.M
B	3-100	Brackets, open, side wall fixing	6	NO.
C	3-051	Closed end piece	2	NO.
D	3-002	Lock joint plate	1	NO.
E		Bolts for brackets (by others)	6	NO.
F	3-217	Hanger end pattern	1	NO.
G	3-221	Hanger centre pattern	1	NO.
H	95-545	Foldaside aluminium hinges S.A.A.	2	PACKS
J	95-547	Foldaside aluminium hinges S.A.A.	1	PACK
K	95-551	Foldaside brass hinges S.C.	1	PACK
L	44-317	Bottom guide end pattern	1	NO.
M	44-321	Bottom guide centre pattern	1	NO.
N	44-2	Floor channel, aluminium 2 x 1.8m	3.6	LIN.M
or N	44-3	Floor channel, brass 2 x 1.8m	3.6	LIN.M
O	95-677	Flush bolt S.A.A.	2	NO.
P	95-617	Flush handle S.C.	3	NO.

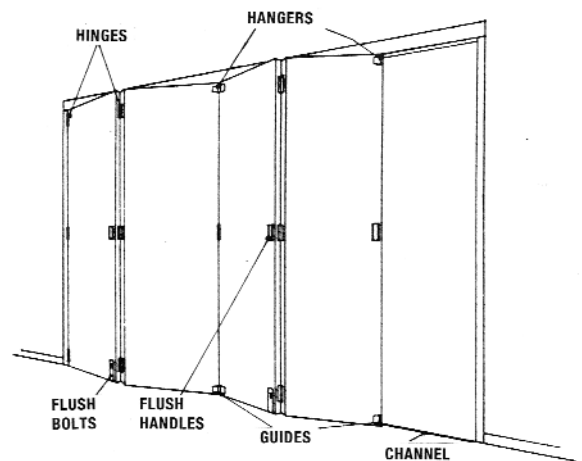



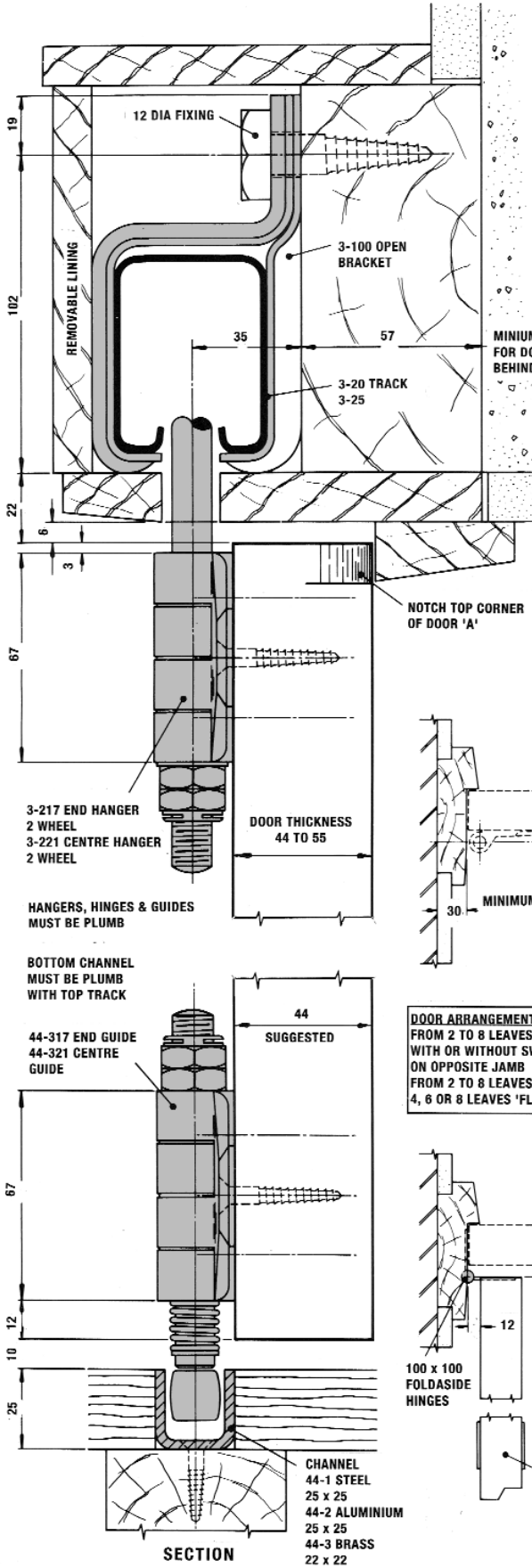

STANDARD TRACK LENGTHS				
1.8	2.1	2.4	3.0	METRES

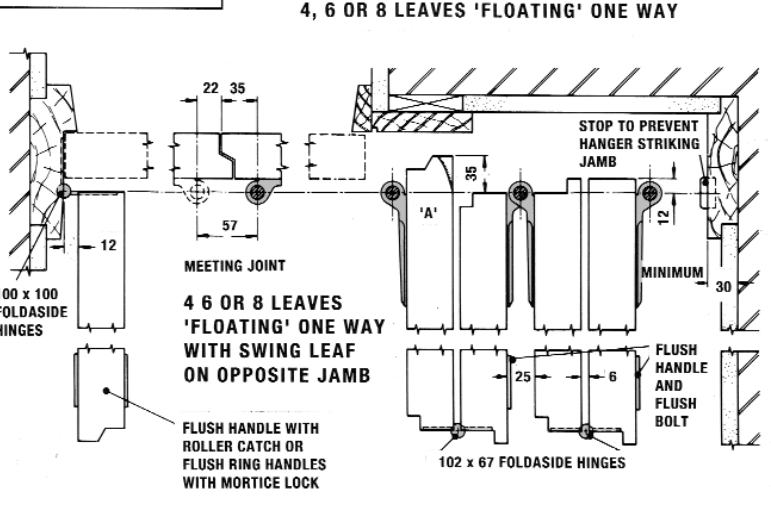
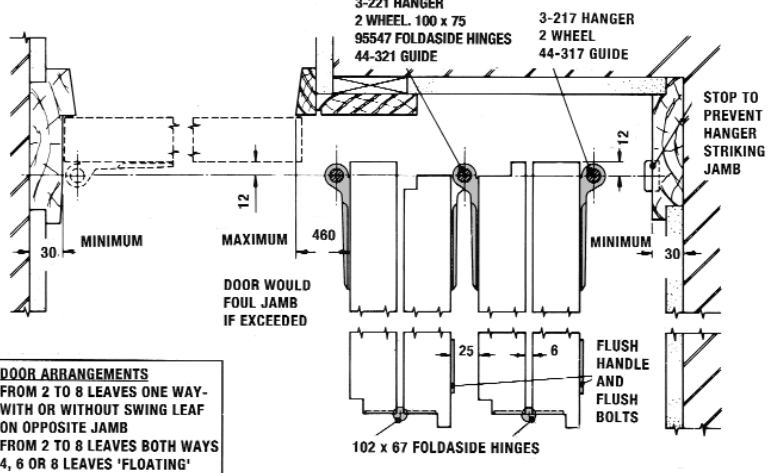
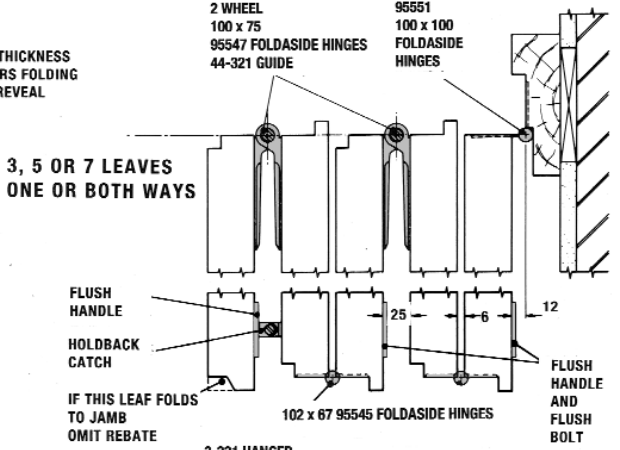
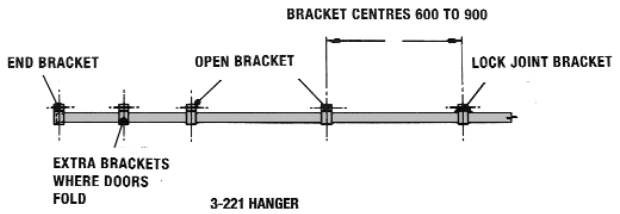

Hillaldam Coburn has a history of commitment to quality and technical developments. Products are always manufactured to the appropriate British Standards and the company was one of the first in the industry to have operating procedures approved under BS EN ISO 9001.

Constant testing ensures that quality is maintained and a programme of product improvement is regularly reviewed and updated.

The following range of literature is available on request:

### SLIDING DOOR GEAR

- Centafold & Foldaside
- Façade
- Foldaside & Cornaway
- Glassmaster 80
- Glassmaster Kabinette
- HIDEAWAY™ Pocket Door Kit
- HIDEAWAY™ Protek
- Interior Sliding Systems
- Interior Track Sets
- Fire Rated Straightaway 320
- Straightaway Door Gear
- Straightaway 50
- Straightaway 100ss
- Straightaway 700ss
- The Buyers Guide

### OTHER COBURN PRODUCTS

- Dictator Range of products
- Folding Fabric Partitions
- Movable Walls
- Rediframe® Steel Door Frames



Follow us on twitter @SalesCoburn

**facebook**

Keep up to date with our latest news on Facebook



Certificate No. 14679

The products designed and supplied by Hillaldam Coburn Ltd are covered by a Quality Assurance system in accordance with BS EN ISO 9001:2008

The company reserves the right from time to time to make such alteration in design and manufacture as it considers necessary without notice. Drawings, specifications, illustrations, tables and other details are not binding in detail. Conditions of sale are as those published on the Company's tender forms.

## HILLALDAM COBURN LIMITED

UNIT 16, MERTON INDUSTRIAL PARK, LEE ROAD, LONDON, SW19 3HX, UK

Tel: +44 (0) 20 8545 6680 Fax: +44 (0) 20 8545 6720 Email: [sales@hillaldam.co.uk](mailto:sales@hillaldam.co.uk) Web: [www.coburn.co.uk](http://www.coburn.co.uk)