

For lapped (outset) doors

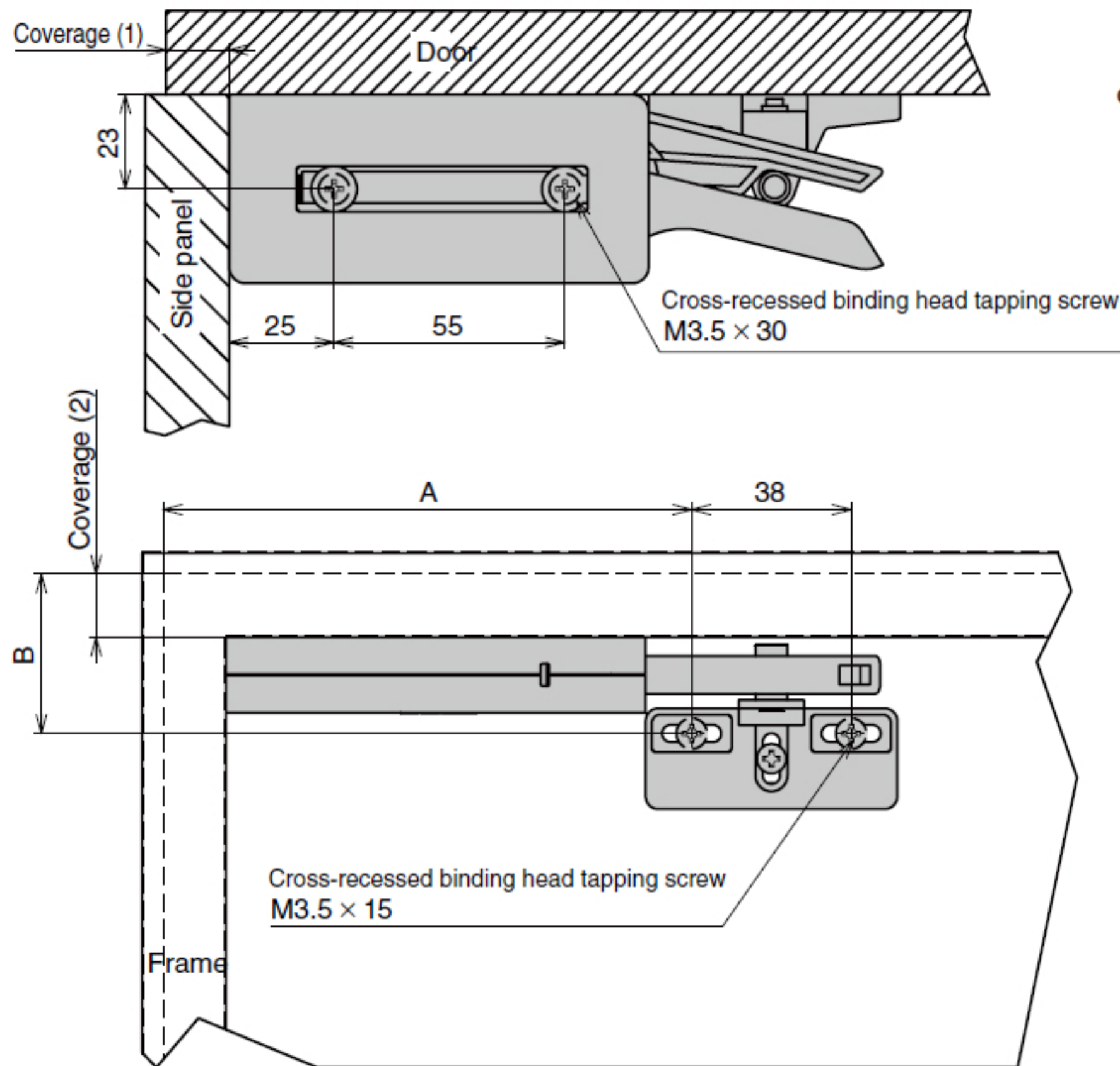

For inset doors

Install a door stopper in addition to this product.

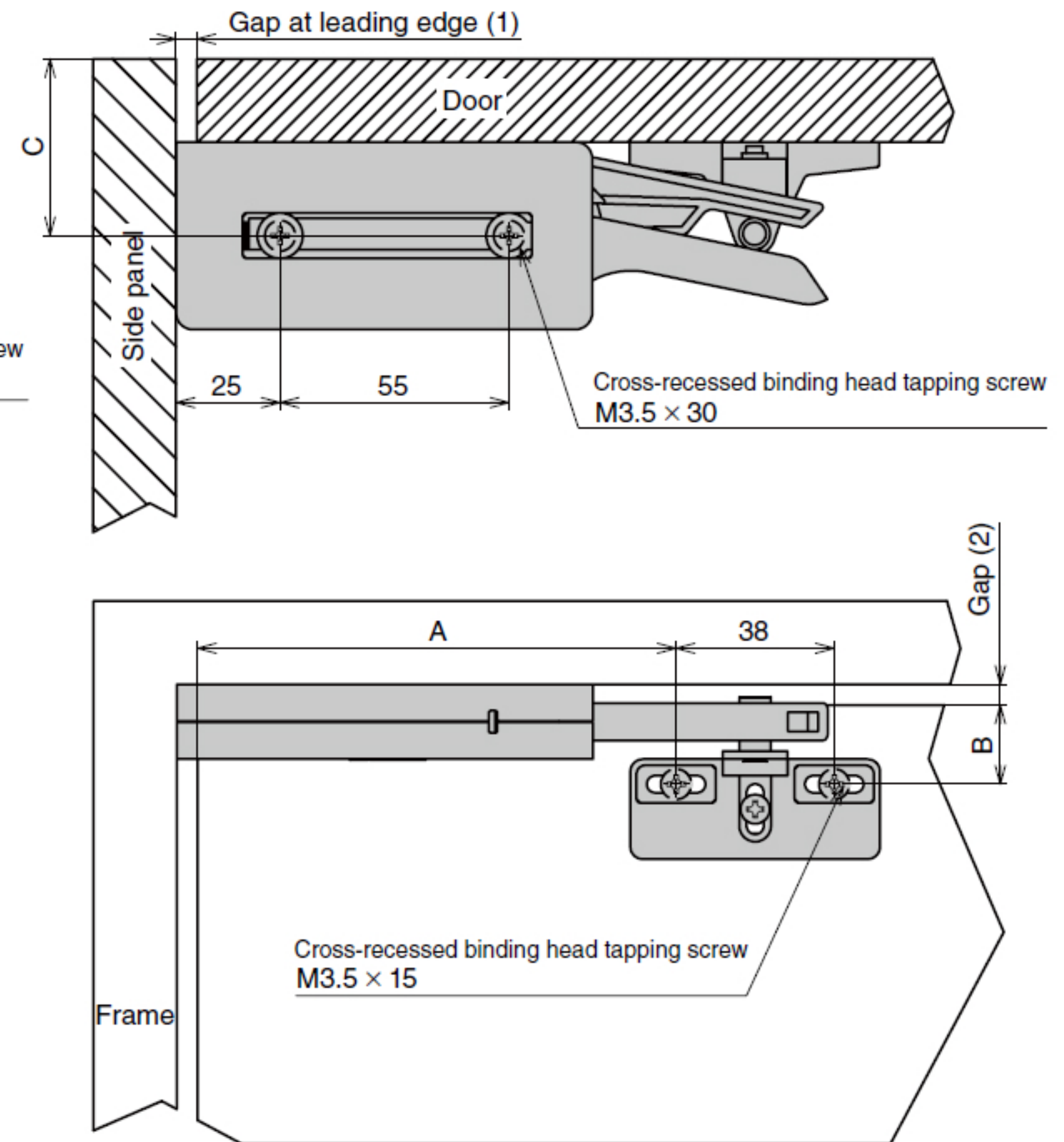

	A	B	C
Outset Doors	114 + Coverage (1)	24 + Coverage (2)	/
Inset Doors	114 - gap at leading edge (1)	24 - gap (2)	

ARCHITECTURAL
DOOR HARDWARE

Related Products

ONE-TOUCH SLIDING HINGE FOR HEAVY DOORS 80230

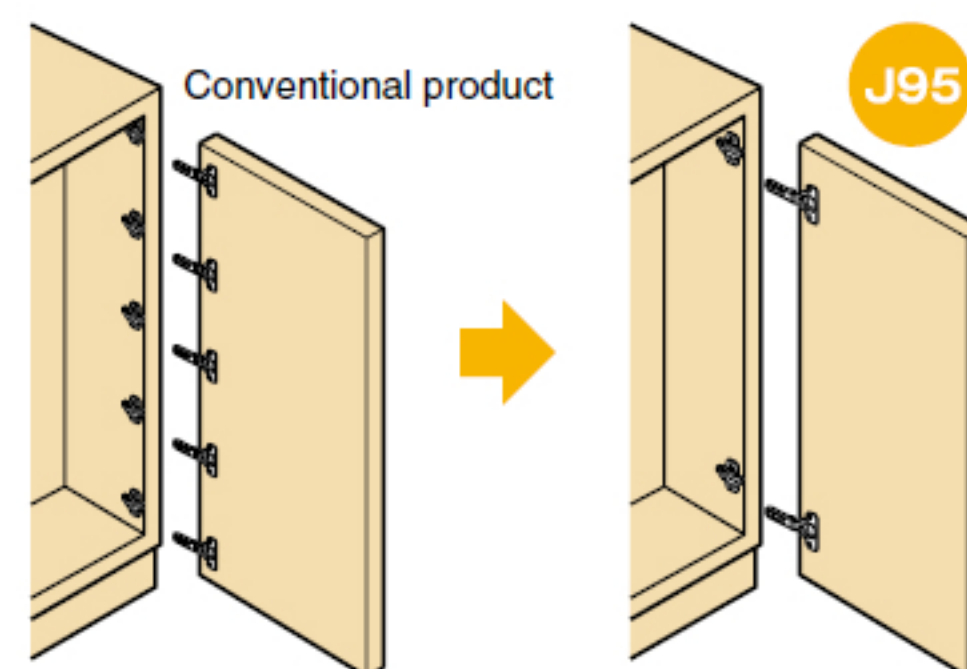

Two pieces will do the job of five conventional hinges!

Features

- A sliding hinge for heavy doors that can be used together with the DC-200 damper catch.
- Use the type with a catch if **using together** with the DC-200 damper catch.
- Supports large doors weighing up to 25 kg with 2 hinges or up to 40 kg with 3 hinges.
- Enables one-touch installation and removal of the door.
- Enables three-dimensional adjustment of the door.
(+1.5 mm/-2.5 mm forward/back, ±3 mm up/down, +0 mm/-4 mm coverage adjustment [left/right])
- Streamlined design free of protrusions such as adjustment screws on the body top.
To ensure safety, the lock lever does not protrude from the back of the body.

DAMPER CATCH