

Surface Mounted Rack & Pinion Overhead Door Closer

24046

EN2-5 power adjustable by spring door closer



- Extruded Body
- Rack and Pinion mechanism with matching flat form armset
- Adjustable closing speed and latch action
- Backcheck
- Universal Application (Fig 1, Fig 6 & Fig 61)
- Slimline Rectangular, Semi Radius
- Grade 304 material is specified for all stainless steel covers
- Capable of meeting the requirements of BS8300 and Approved Document M

Technical Data

 **Declaration of Performance:**
Available upon request

 **Certifire Certificate No.:**
CF 5294

 **Classification:**
Fig 1

| | | | | | |
|---|---|---------------|---|---|---|
| 4 | 8 | $\frac{5}{2}$ | 1 | 1 | 4 |
|---|---|---------------|---|---|---|

Fig 6

| | | | | | |
|---|---|---------------|---|---|---|
| 3 | 8 | $\frac{4}{3}$ | 1 | 1 | 4 |
|---|---|---------------|---|---|---|

CE Certificate No.:
1121-CPD-AD5196

Available Cover & Arm Finishes

Metallic Finishes



PBB PSC SES SSN

RAL Colours available to Special Order



SDS LONDON

Fixing Instructions for : 24046 Door Closer Power Adjustable EN 2-5

| | | | |
|------------|--|---------------|-------------|
| CE 1121 | Synergy Hardware Limited Lifford Lane, Kings Norton, Birmingham B30 3JN | CPR AD5196 | 15 |
| | | | |
| 4 | 8 | 5 2 | 1 1 4 |



Regular Fixing

1

Using the templates provided, mark and drill pilot holes into the door and frame.

2

Using the templates provided, fix the mechanism to the door as well as the armset and any necessary brackets.
PLEASE NOTE If a cover is to be fitted over the mechanism, the template for this arrangement can be found with the cover itself and should be referred to at this point.

3

Attach the armset to the mechanism ensuring the pre-loading requirement has been completed.

4

Operate door closer in order to check operation.

- ★ **Backcheck Adjustment**
To increase the backcheck action, turn the valve clockwise. To decrease, or to turn off backcheck, turn the valve counter clockwise.
- ★ **Adjust the Closing & Latching speed.**
 1. The door closer can control two different speeds.
 2. The No.1 speed-adjusting valve controls the Closing speed, and the No.2 speed adjusting valve controls the Latching speed.
- ★ **Delayed Action (optional)**
To delay the closing action of the unit adjust valve No.3

Installation Instructions: Please refer to actual size template for exact fitting dimensions

Pre-Loading of Arm

For the unit to provide the optimum performance and overcome any resistance upon closing it is recommended that the armset is "pre-loaded". To pre-load, reposition the fixing angle of the arm onto the mechanism so that the end of the closing cycle would be past the stop position, as indicated below.

Before After

Adjustment Details

This unit is a power adjustable mechanism. Power / force adjustment is carried out by a single adjustment valve in the end of the mechanism. The unit is pre-set in the factory at EN size 3. Please see table below for adjustment details for each power size.

The following adjustment valves have a maximum adjustment of 1 full turn per valve. **PLEASE NOTE** over adjustment will damage the mechanism and/or the performance of the door closer and invalidate its guarantee.

Adjust Backcheck (valve #4) and the optional Delayed Action (valve #3) before adjusting the Closing Speed (valve #1) and Latching Action (valve #2).

Fixing in Fig.1 / Fig.61

| Power size | Max. Door width | Max. Door weight | Max. Door opening | Number of turns |
|------------|-----------------|------------------|-------------------|-----------------|
| 2 | 850mm | 40Kg | 180° | 8CCW |
| * 3 | 950mm | 60Kg | 180° | 0 |
| 4 | 1100mm | 80Kg | 180° | 7CW |
| 5 | 1250mm | 100Kg | 180° | 7CW |

* Factory preset
CW:Clockwise CCW:Counterclockwise

Installation and Maintenance Instructions:

Warning

1. Please note the minimum power size requirement for fire / smoke door assemblies is 3 as required by Approved Document B.
2. Do not install mechanical hold open devices on fire / smoke door assemblies.
3. Take care not to exceed the maximum opening angle as detailed above.
4. Care and attention must be taken when adjusting any of the units control valves to avoid damage through over adjustment.
5. All closer units are sealed for life and the internal components assembled under high load, therefore, tampering with the mechanism is to be strictly avoided.

After Installation

1. When the closer operates to close the door from its maximum opening position, it should ensure the lock latchbolt and any seals are overcome and the leaf returned into its frame.
2. When the door is slightly open and the latch bolt resting against the strike, release the door to ensure the leaf fully closes into its frame.

Maintenance

1. Once the unit has been correctly fitted it is recommended that periodic checks (every six months) are carried out to ensure all fixings are tight and the door closes freely and positively into the frame, without slamming.
2. A light oil lubricant (non-graphite) should be applied to the moving joints and exposed pivot points.



SDS LONDON

Fixing Instructions for : 24046 Door Closer Power Adjustable EN 2-5

| | | | | | | |
|------------|--|---------------|-------------------------|---|---|--|
| CE 1121 | Synergy Hardware Limited Lifford Lane, Kings Norton, Birmingham B30 3JN | CPR AD5196 | 15 | | | |
| | | | BS EN1154:1997+ A1:2002 | | | |
| 4 | 8 | 5 2 | 1 | 1 | 4 | |

Warrington
certified
certification

APPROVED
PRODUCT
CF5294

Parallel Fixing

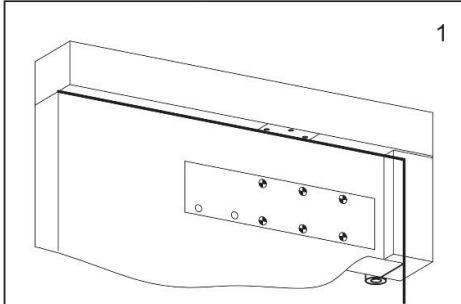

Using the templates provided, mark and drill pilot holes into the door and frame.

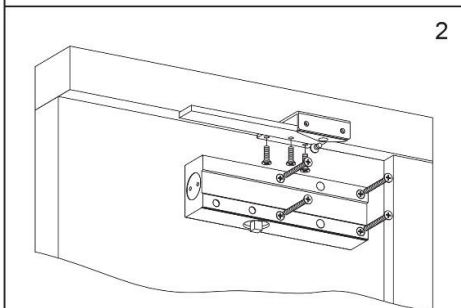

Using the templates provided, fix the mechanism to the door as well as the armset and parallel arm bracket.

PLEASE NOTE If a cover is to be fitted over the mechanism, the template for this arrangement can be found with the cover itself and should be referred to at this point.

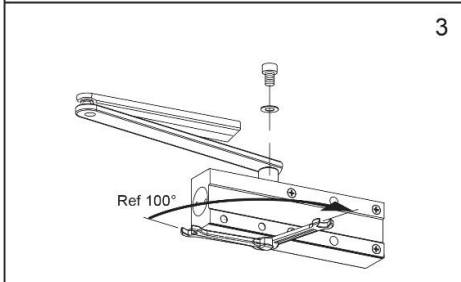

Rotate the bottom pinion to approximately 100° with a wrench as illustrated and then assemble the main arm.

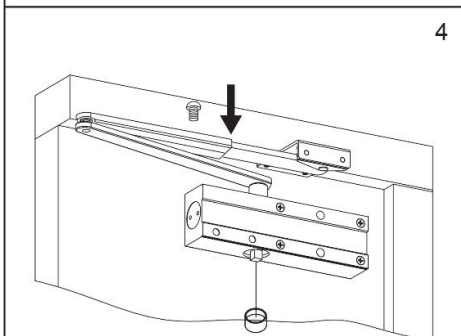

Make sure the main arm is parallel to the door. Then attach the connecting arm.

Dimensions: 175, 54, 43, 50, 50, 236, 48, 130, 11

Labels: Main arm, Link arm, parallel arm bracket

Fixing in Fig.66

| Power size | Max. Door width | Max. Door weight | Max. Door opening | Number of turns |
|------------|-----------------|------------------|-------------------|-----------------|
| * 3 | 950mm | 60Kg | 130° | 0 |
| 4 | 1100mm | 80Kg | 130° | 7CW |

* Factory preset
CW:Clockwise CCW:Counterclockwise

Dimensions: 54, 175, 43, 50, 50, 236, 130, 48, 11

Labels: Main arm, Link arm, parallel arm bracket

Fixing in Fig.66

| Power size | Max. Door width | Max. Door weight | Max. Door opening | Number of turns |
|------------|-----------------|------------------|-------------------|-----------------|
| * 3 | 950mm | 60Kg | 130° | 0 |
| 4 | 1100mm | 80Kg | 130° | 7CW |

* Factory preset
CW:Clockwise CCW:Counterclockwise

