

PORTMAN

PC21/22/23 gravity closer & electromagnet system Fitting Instructions

24 VOLT SYSTEM

For use with doors 755-1500mm wide
and 44mm thick only.

For Single and Double doors.

Components

Closer mechanism

- Door weight assembly with nylon cord
- Aluminium track.
- Top pulley assembly.
- Damper and activator.
- Cord adjuster.
- Weight support bracket.
- Electromagnet holdback set.
- Magnet door plate set.

Fixing items

- Screw set A.
No8 x 1 1/4" wood screws x 10.
- Screw set B.
No6 x 1" wood screws x 5.
- Screw set C.
No8 x 1 3/4" wood screws x 4.

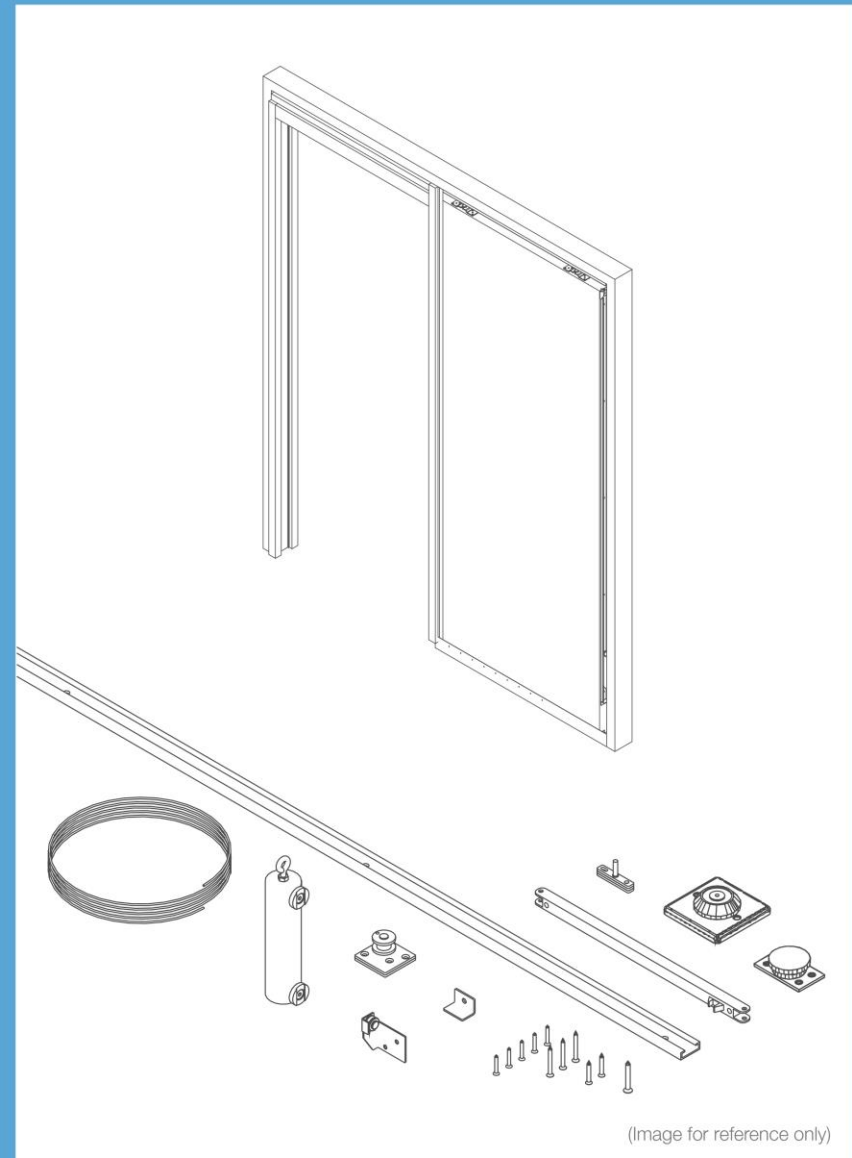

PRE-DOOR FITTING INFORMATION

Firstly construct a studwork frame on which to affix the pocket door system. Portman doors are designed for 100mm studwork. It is crucial that the frame is constructed square and plumb. Measure door and studwork heights from the **finished floor level**.

KEY

- W Studwork width
- H Studwork height
- Op Door opening width
- Oh Door opening height
- Wp Door width
- Hp Door height

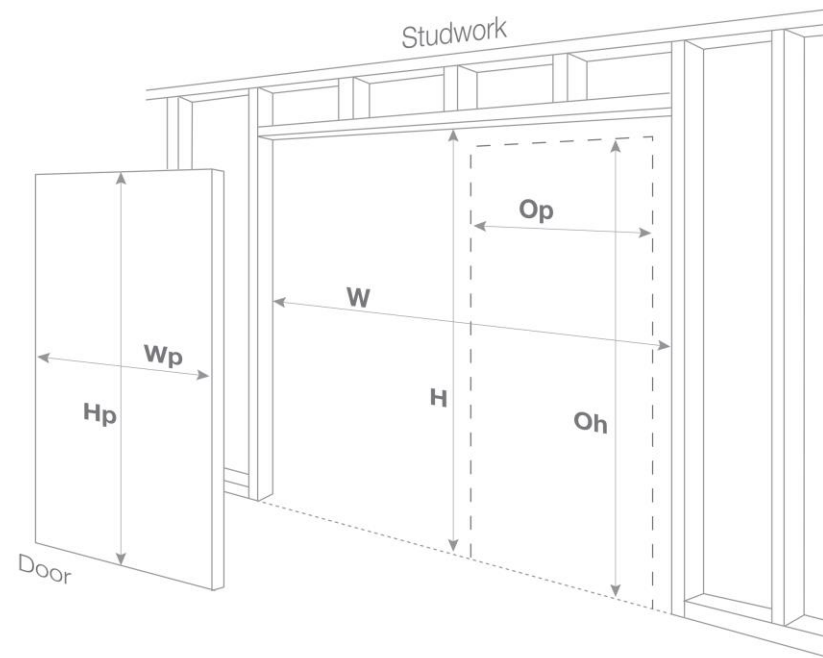

P7001 kits

Single Doors	Double Doors
To calculate studwork width and height from known door dimensions	
Studwork width (W) = (2 x Door width (Wp)) + 51mm	Studwork width (W) = (4 x Door width (Wp)) + 64mm
Studwork height (H) = Door height (Hp) + 85mm	Studwork height (H) = Door height (Hp) + 85mm
To calculate door size from known studwork dimensions	
Door width (Wp) = (Studwork width (W) - 51mm) / 2	Door width (Wp) = (Studwork width (W) - 64mm) / 4
Door height (Hp) = Studwork height (H) - 85mm	Door height (Hp) = Studwork height (H) - 85mm
To calculate door size from known door opening dimensions	
Door width (Wp) = (Door Opening Width (Op)) + 23mm	Door width (Wp) = (Opening Width (Op) + 34mm) / 2
Door height (Hp) = (Door Opening Height (Oh)) + 4mm	Door height (Hp) = (Door Opening Height (Oh)) + 4mm
To calculate door opening width and height from known door dimensions.	
Door Opening Width (Op) = Door Width (Wp) - 23mm	Door Opening Width (Op) = (2 x Door Width (Wp)) - 34mm
Door Opening Height (Oh) = Door height (Hp) - 4mm	Door Opening Height (Oh) = Door height (Hp) - 4mm

PFD30 kits

Single Doors	Double Doors
To calculate studwork width and height from known door dimensions	
Studwork width (W) = (2 x Door width (Wp)) + 20mm	Studwork width (W) = (4 x Door width (Wp))
Studwork height (H) = Door height (Hp) + 85mm	Studwork height (H) = Door height (Hp) + 85mm
To calculate door size from known studwork dimensions	
Door width (Wp) = (Studwork width (W) - 20mm) / 2	Door width (Wp) = (Studwork width (W)) / 4
Door height (Hp) = Studwork height (H) - 85mm	Door height (Hp) = Studwork height (H) - 85mm
To calculate door size from known door opening dimensions	
Door width (Wp) = (Door Opening Width (Op)) + 95mm	Door width (Wp) = (Opening Width (Op) + 131mm) / 2
Door height (Hp) = (Door Opening Height (Oh)) + 33mm	Door height (Hp) = (Door Opening Height (Oh)) + 33mm
To calculate door opening width and height from known door dimensions.	
Door Opening Width (Op) = Door Width (Wp) - 95mm	Door Opening Width (Op) = (2 x Door Width (Wp)) - 131mm
Door Opening Height (Oh) = Door height (Hp) - 33mm	Door Opening Height (Oh) = Door height (Hp) - 33mm

Step 1

Damper body

NOTE: PLEASE FIT DAMPER BEFORE FITTING THE DOOR INTO THE POCKET.

- A.** Fit the soft close damper to the top of the door, fitted up against the Hangar Bracket closest to the leading edge of the door, set back 5mm away from the door face. Ensure the damper body is fitted so that the trigger is closest to the leading edge of the door in its armed condition.

At this point, fit the door as per the instructions of the kit you are fitting.

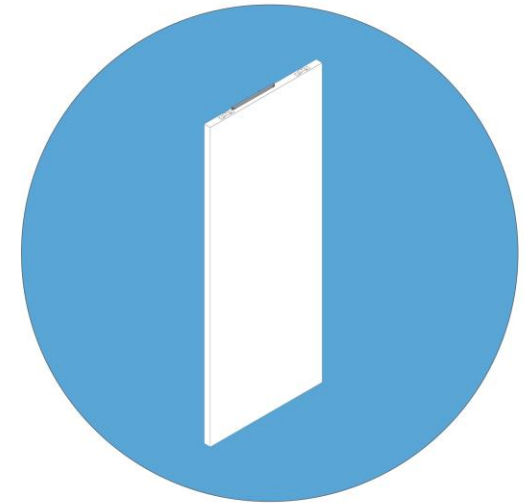
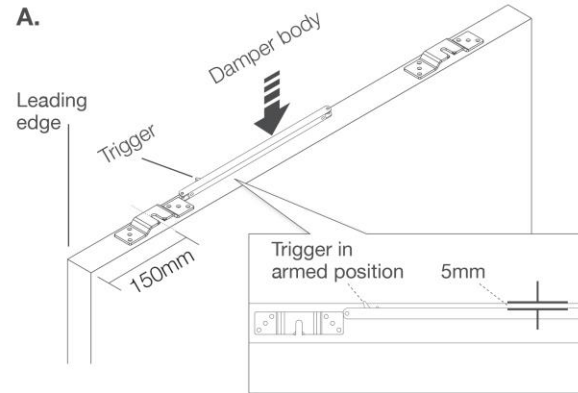

Step 2

Damper activator

- A.** Position the centre of the damper activator on the track packer, 340mm (345mm for double doors) away from the inside face of the closing jamb. Ensure the long edge of the damper activator is butted up along the edge of the track packer. Fix the damper activator using the pan head wood screws supplied in the damper fixing pack. Enclosed height adjusters may be required to ensure full engagement in the damper.

Dimensions given are approximate and may need altering for your individual kit.

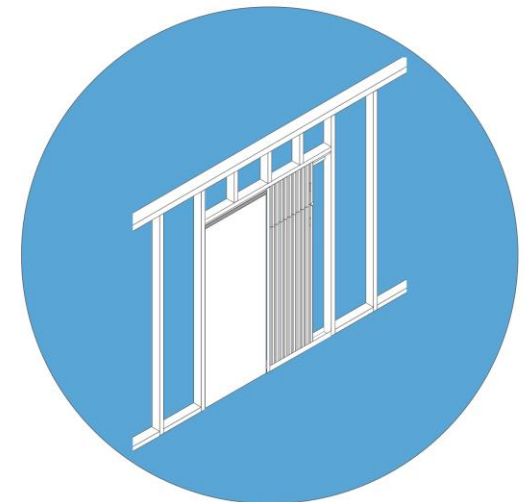
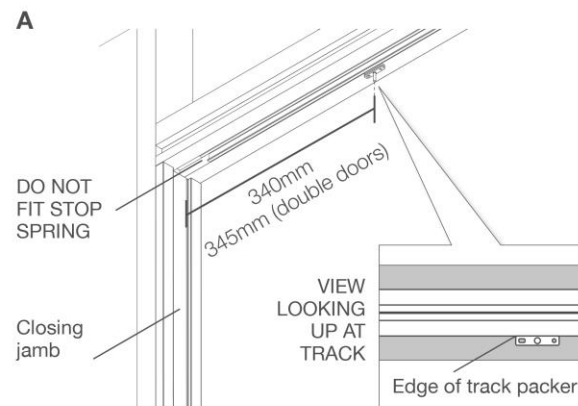

Step 3

Electromagnet installation

IMPORTANT: To allow for easy installation of the Gravity Closer and Electromagnet System, leave the fitting of one side of the 'Z section panels, closing jamb and head jamb.

- A.** Screw fix the back box supplied central to the width of the pocket end studwork, 100mm above the finished floor level.

Drill a hole through the back box and studwork to allow for the electromagnet wires to pass through and fit the back box in place with **'Screw set A'**.

The unit is supplied with a test/release button, which must be fixed in a suitable location. Additional normally closed switches can be connected in series if required.

- B.** Drill a 12mm diameter counter-bore, 6mm deep into the back edge of the door, level with the centreline of where the electromagnet has been fitted. Fit the Door Plate Set into the counter-bore in the door using **'Screw set A'**.

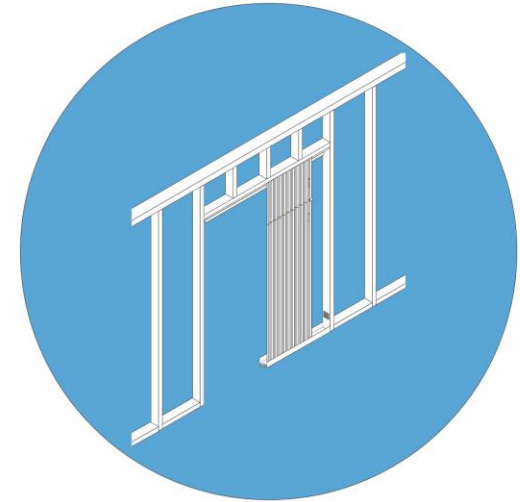
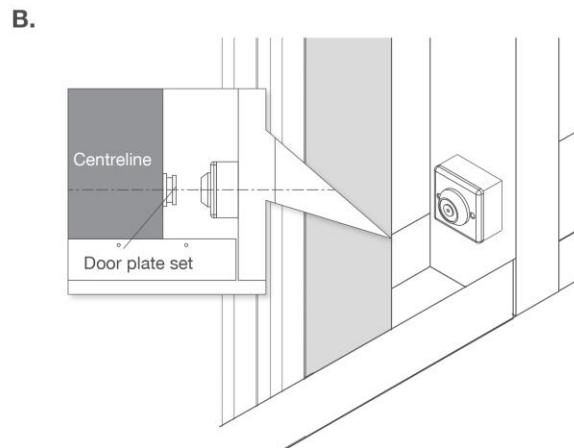
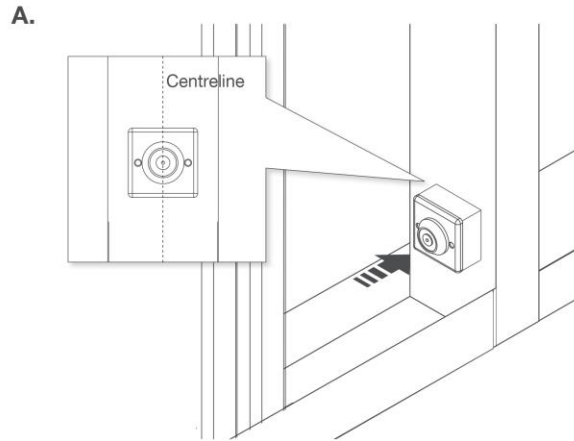

WIRING

The power supply to this door retainer must be controlled by the buildings fire detection system. For mains powered interconnected smoke alarm systems, a relay base from the smoke alarm manufacturer can usually be used. The door will be held open when power is supplied to the unit and released when it is disconnected. It is recommended that this fire door retainer is installed by a NACOSS/NSI certified electrician.

PC21/22/23 SPECIFICATION

Current@ 24Vdc / 50mA. Maximum cable size 2.5mm². Suitable 24 Vdc power supply required.

Step 4

Pulley assembly and track

- A.** Using **'Screw Set A'**, pilot and screw fix the pulley assembly centrally to the back edge of the door leaf, ensuring it is flush with the top edge of the door.

Using **'Screw Set B'**, fix the track through the countersunk holes into the back edge of the door. Ensure the track is fitted centrally to the door leaf. NOTE: The track may require cutting to length. Ensure there is 160mm gap from the bottom of the door leaf to the bottom of the track.

Hang the door as per the door fitting instructions.

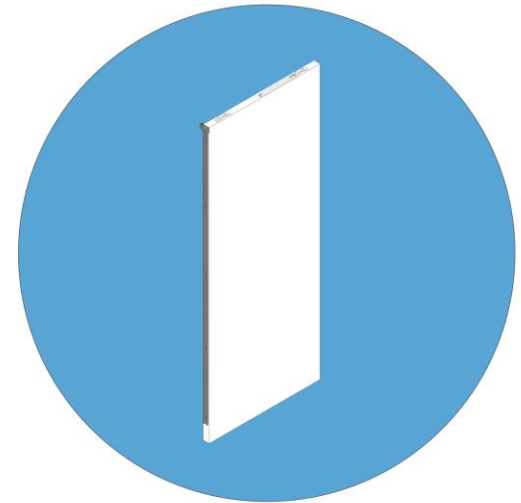
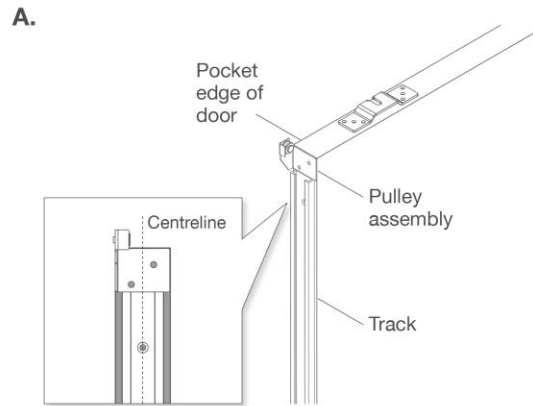

Step 5

Tensioner

For single door kits

For double door kits, please proceed to Step 5A.

- A.** Ensure the tensioner is fitted in line with the pulley wheel. Screw fix the cord tensioner assembly at the closing jamb using **'Screw Set B'**.

Wherever possible ensure the screws go into solid timber and avoid screwing into timber joints.

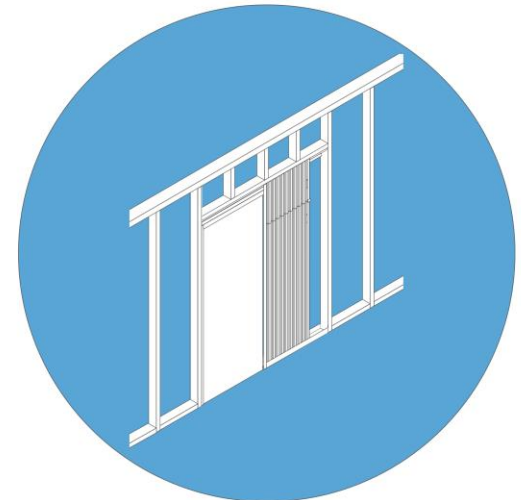
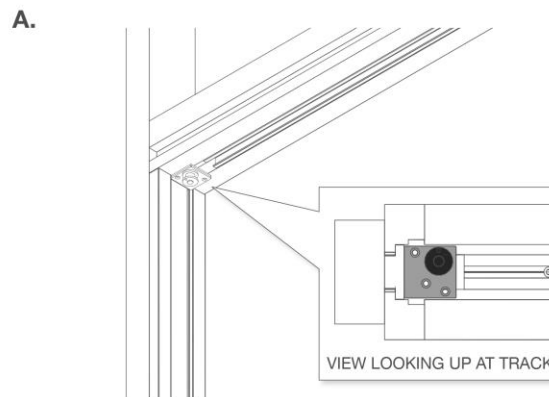

Step 5A

Tensioner

For double door kits

- A.** Ensure when fitting the tensioners they are up against the centreline between cassette jamb edges.

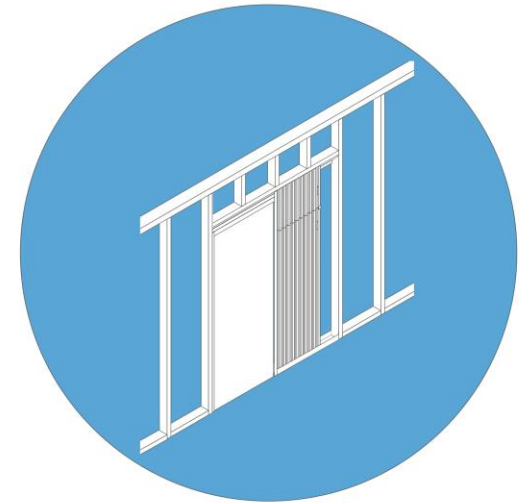
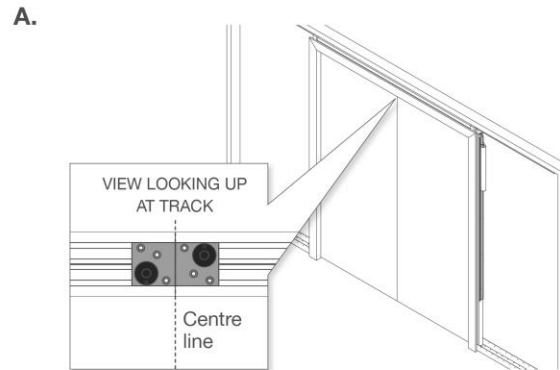

Step 6

Weight assembly and support bracket

- A.** Feed the plastic guides of the weight assembly into the track, with the cord facing upwards.
After fitting the weight, screw fix the support bracket below the track.

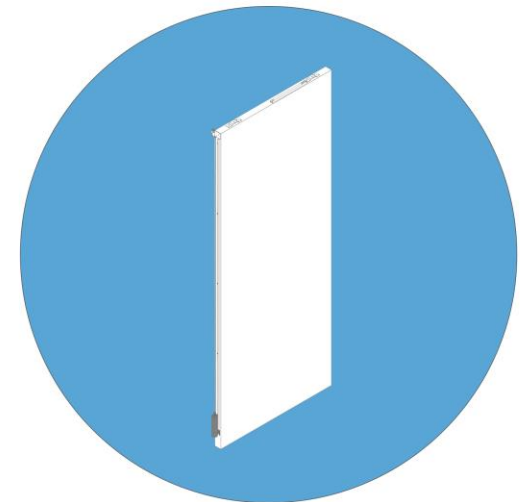
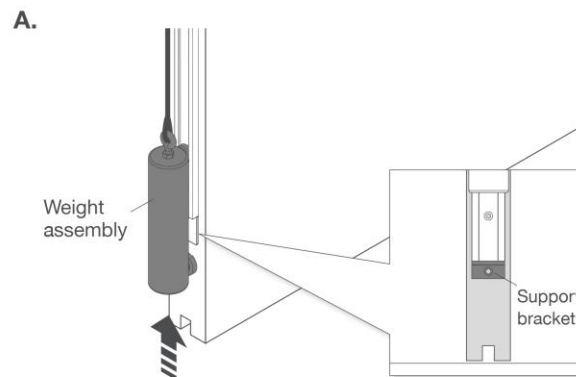

Step 7

Pulley cord assembly

- A.** Pass the cord around the plastic pulley wheel of the top pulley assembly
- B.** Secure the door fully open. Thread the cord through the hole in the wheel of the cord tensioner assembly. Ensure it is threaded from inside to out and to the left hand side of the wheel assembly.
- C.** With the door fully open, pull the cord through the tensioner wheel, raising the weight to just below the top pulley bracket. Securely knot the cord to the tensioner and then operate the door to ensure all components are correctly fitted, prior to cutting off the remaining cord.

FOR DOUBLE DOOR KITS, PLEASE REPEAT STEPS 1-7 FOR THE SECOND DOOR.

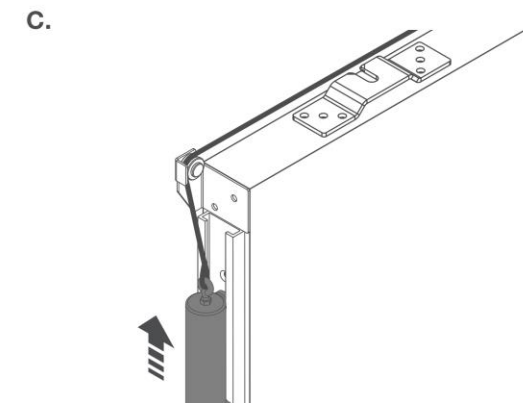
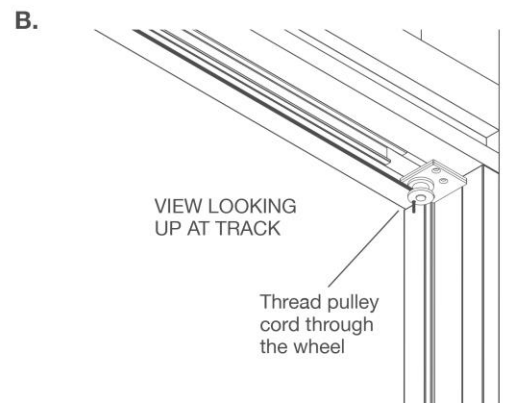
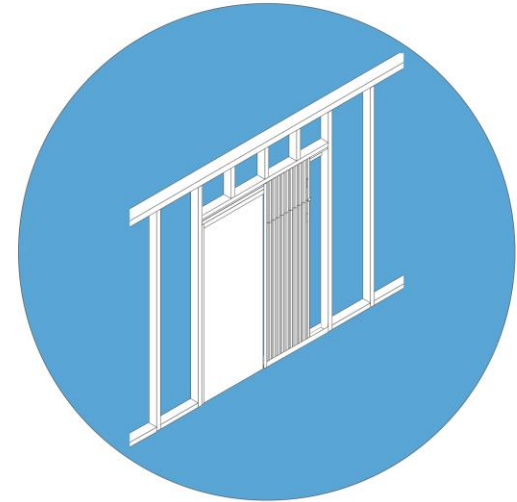
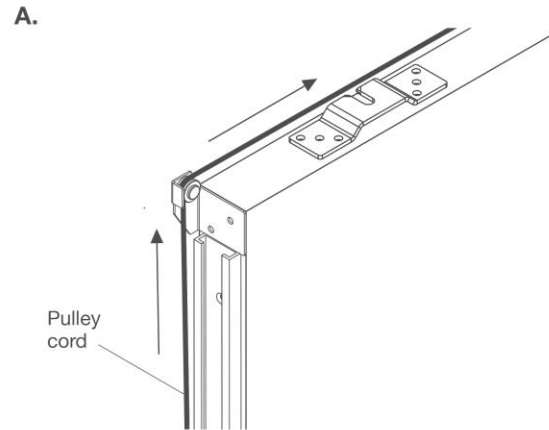

PORTMAN