

P7001 Standard Glass Door Kit FITTING INSTRUCTIONS

For Single and Double doors



(Image for reference only)

SUGGESTED TOOLS



DRILL



MITRE/CHOP SAW



TAPE MEASURE



HACKSAW



PLUMB LINE



HANDSAW



SPIRIT LEVEL



PROTECTIVE EQUIPMENT

COMPONENTS

POCKET DOOR KIT

- SHORT / LONG 'Z' SECTION
- LONG 'Z' SECTION
- TRACK PACKER
- PLYWOOD TRACK MOUNT
- ALUMINIUM TRACK
- DOOR BOTTOM CHANNEL
- SOLE PLATE
- GLASS CLAMP KIT
- BRUSH SEAL
- RUBBER STOPPERS

DOOR JAMB SET

- FRONT EDGE JAMB
- CASSETTE EDGE JAMB

SLIDING MECHANISM

- TROLLEY CATCH
- TROLLEY ASSEMBLY
- FLOOR GUIDE

FIXING ITEMS

- END BLOCK
- PROTECTIVE EDGE CLIP
- CHOCK LARGE
- CHOCK SMALL
- SCREW SET A
- SCREW SET B
- SCREW SET C
- SCREW SET D
- SCREW SET E
- SCREW SET F

* Quantities are dependant on type of kit ordered

POCKET DOOR KIT

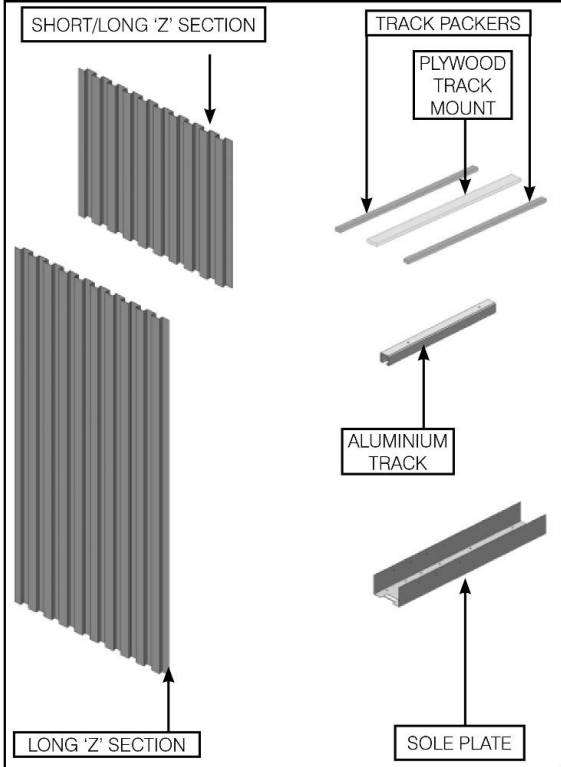

FIXING ITEMS SET

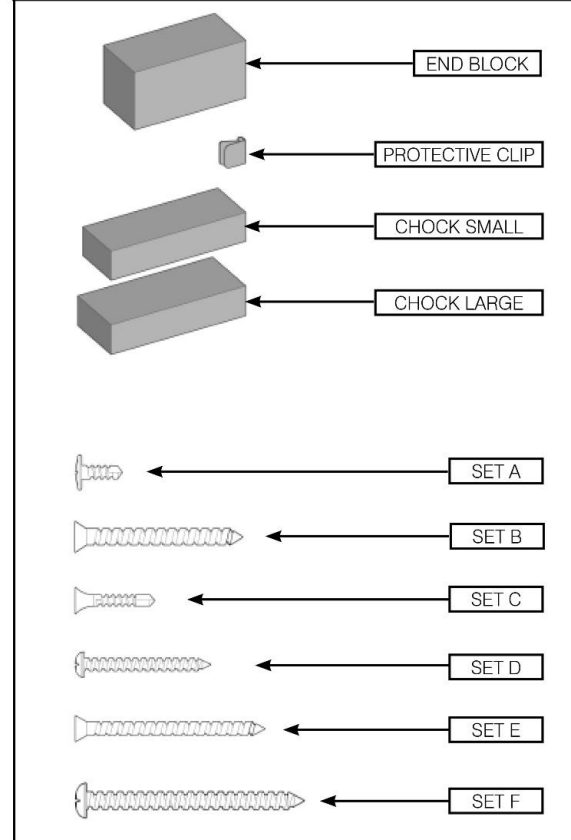

OPTIONAL DOOR JAMB SET

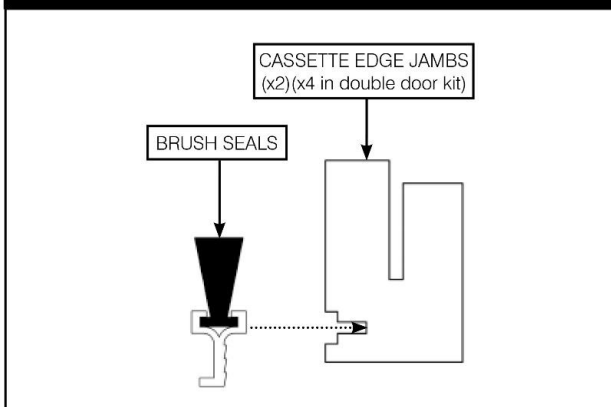

CASSETTE AND FRONT JAMB SUPPLIED IN 2.2m OR 2.8m LENGTHS

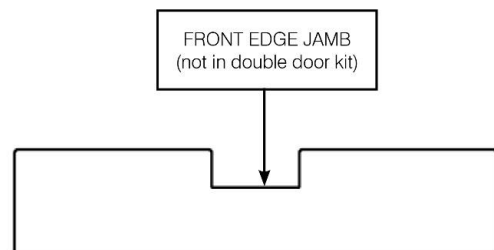

SLIDING MECHANISM COMPONENTS

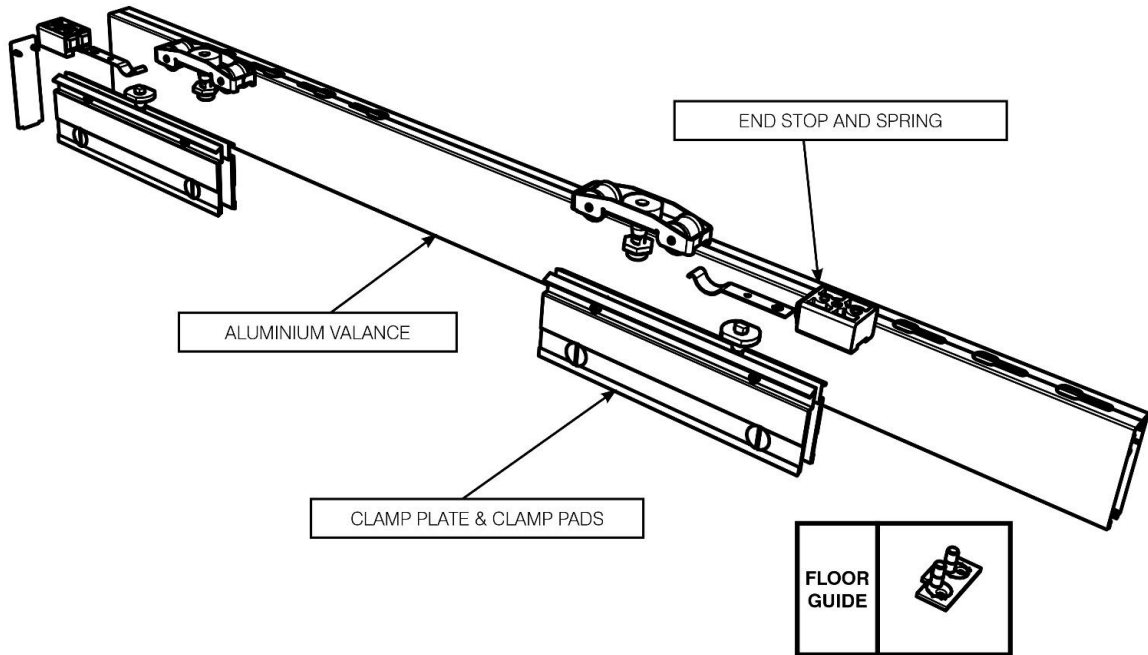

FIXING PACK

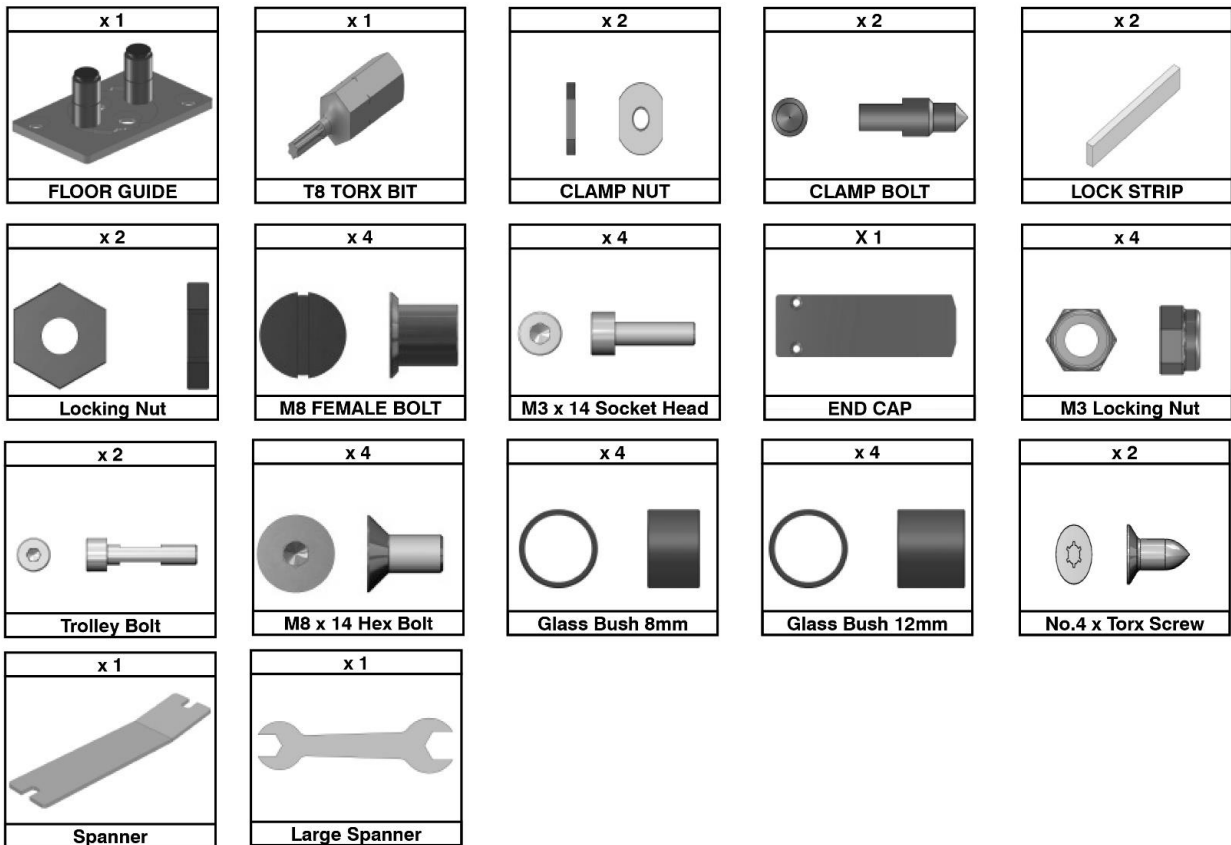

PRE-DOOR FITTING INFORMATION

Firstly construct a studwork frame on which to affix the pocket door system. Portman doors are designed for 100mm studwork. It is crucial that the frame is constructed square and plumb. Measure door and studwork heights from the finished floor level.

Abbreviations	
W	= STUDWORK WIDTH
H	= STUDWORK HEIGHT
Op	= DOOR OPENING WIDTH
Oh	= DOOR OPENING HEIGHT
Wp	= DOOR WIDTH
Hp	= DOOR HEIGHT

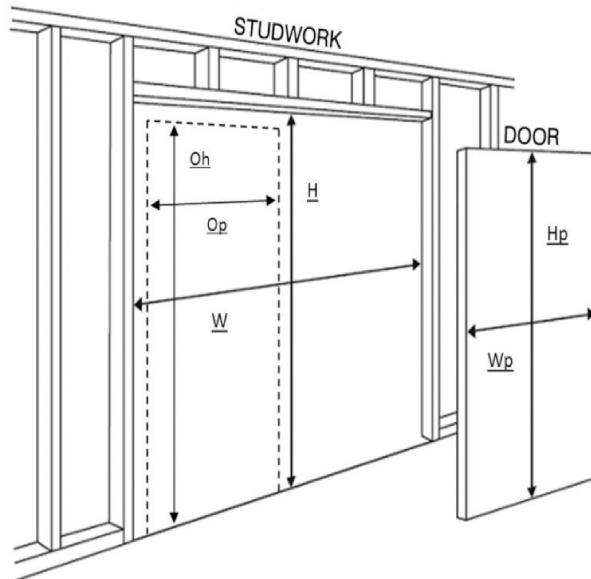

1. To calculate **studwork** width and height from known **door dimensions**:

$\text{Studwork width (W)} = (2 \times \text{Door width (Wp)}) + 11\text{mm}$ $\text{Studwork height (H)} = \text{Door height (Hp)} + 91\text{mm}$
--

$\text{For double doors: (W)} = (4 \times \text{(Wp)}) - 10\text{mm}$ $\text{For double doors: (H)} = \text{(Hp)} + 91\text{mm}$
--

2. To calculate **door size** from known **studwork dimensions**:

$\text{Door width (Wp)} = (\text{Studwork width (W)} - 11\text{mm}) / 2$ $\text{Door height (Hp)} = \text{Studwork height (H)} - 91\text{mm}$

$\text{For double doors: (Wp)} = ((\text{W}) + 16\text{mm}) / 4$ $\text{For double doors: (Hp)} = \text{(H)} - 91\text{mm}$

3. To calculate **door size** from known door **opening dimensions**:

$\text{Door width (Wp)} = \text{Door opening width (Op)} + 23\text{mm}$ $\text{Door height (Hp)} = \text{Door opening height (Oh)} - 47\text{mm}$

$\text{For double doors: (Wp)} = (\text{Op} + 28\text{mm}) / 2$ $\text{For double doors: (Hp)} = \text{(Oh)} - 47\text{mm}$

4. To calculate **door opening** width and height from known **door dimensions**:

$\text{Door opening width (Op)} = \text{Door width (Wp)} - 23\text{mm}$ $\text{Door opening height (Oh)} = \text{Door height (Hp)} + 47\text{mm}$

$\text{For double doors: (Op)} = (2 \times \text{Wp}) - 28\text{mm}$ $\text{For double doors: (Oh)} = \text{(Hp)} + 47\text{mm}$
--

5. To calculate **valance length** width and **cutting positions** from known **door dimensions**:

$\text{Standard width valance length (Vl)} = \text{Door width (Wp)} + 2\text{mm}$ $\text{Standard Width Cutting Position (Vc)} = (929 - \text{Vl}) / 2$

$\text{Intermediate and wide valance length (Vl): (Wp) + 2mm}$ $\text{Intermediate and Wide Cutting Positons: (1503 - Vl) / 2}$

1. TRACK MOUNT

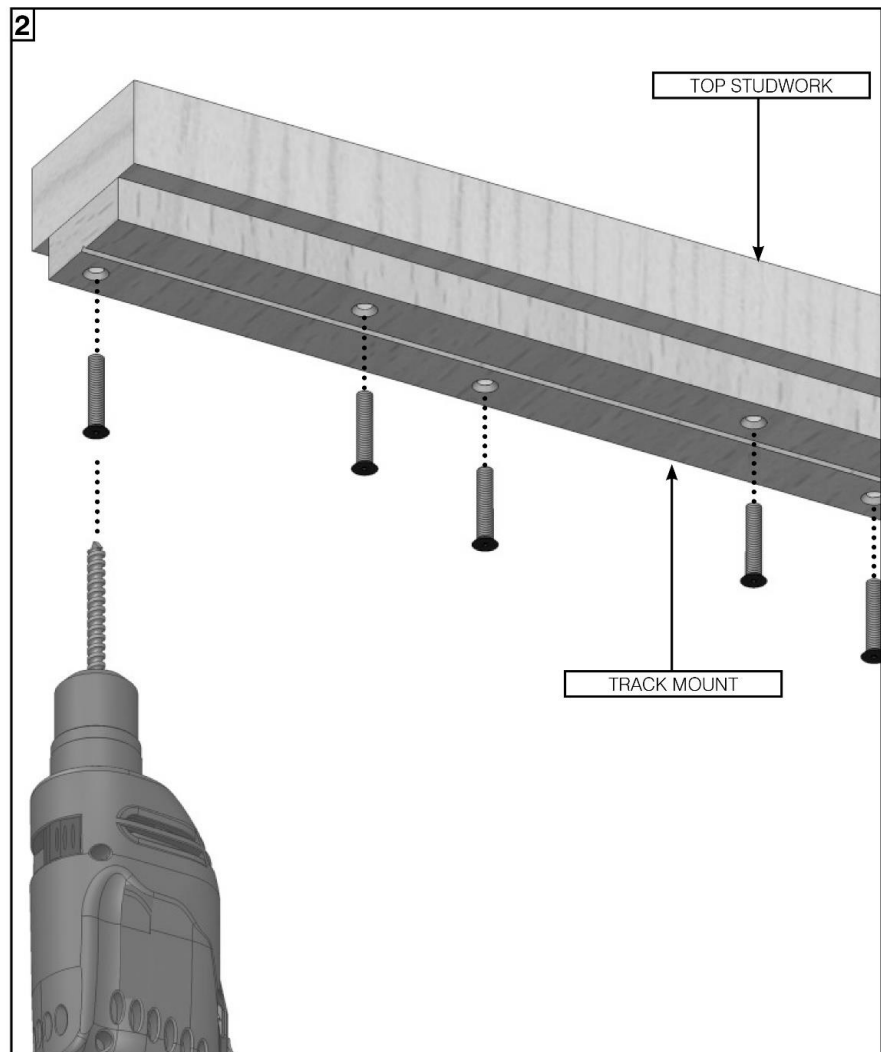
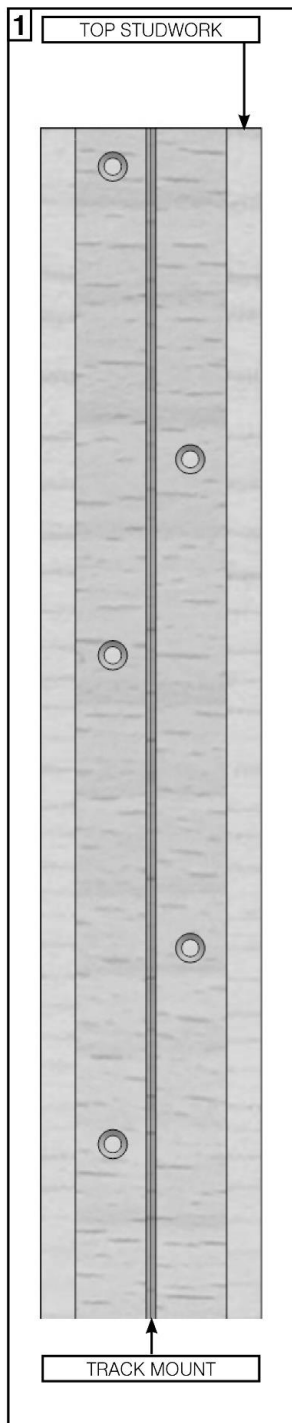

1. Cut the plywood track mount to the width of your horizontal studwork / support frame.

For intermediate, wide and double kits butt the two track mounts together to make up the required length

2. Position the track mount in the centre of the top horizontal studwork timber / support frame.
3. Pilot drill and screw through both sides of 'V' Shaped groove and ensure screw heads are fully sunk into the wood **(Screws not supplied)**.

2. ALUMINIUM TRACK

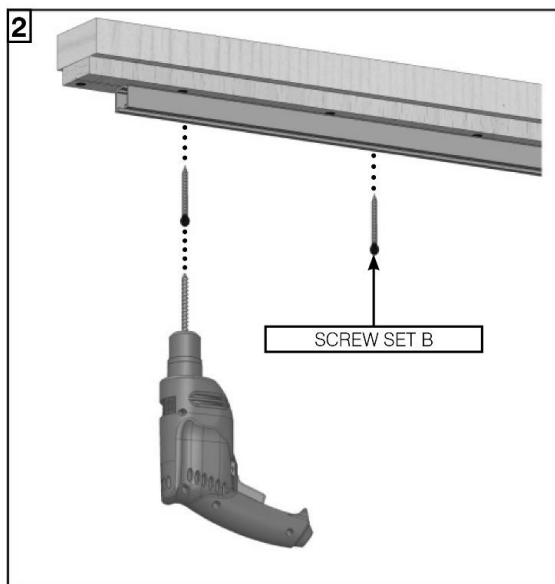
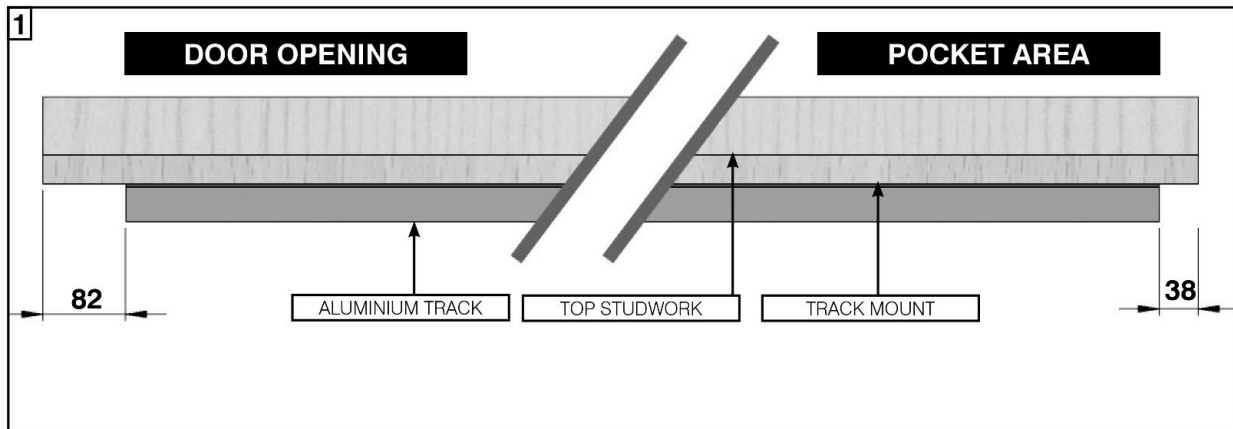

1. For **Single Door Kits**, cut the aluminium track to the width of your horizontal studwork, minus 120mm. Position 82mm in from doorway vertical stud to allow for the end block.
2. Pilot drill through the holes in the track into the 'V' Shaped groove in the plywood track mount. Screwfix using '**Screw Set B**'.

TRACK SHOULD BE WIPED CLEAN TO REMOVE ANY CONTAMINANT

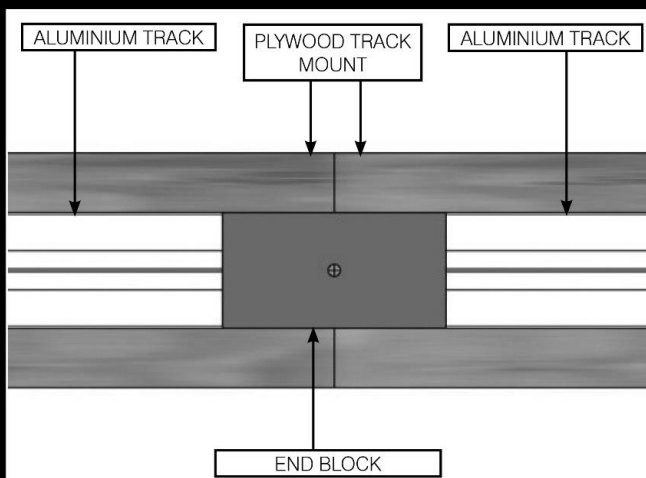

For **Double Door Kits**, cut the aluminium tracks to half the width of your horizontal studwork, minus 70mm.

Position the end block centrally into the plywood track mount and screw into the 'V' shaped groove with '**Screw Set D**'.

Butt the aluminium tracks to it, leaving a gap to the far side of each track and fix into the 'V' shaped groove in the plywood track mount with '**Screw Set B**'.

At this point remove the end block as entry to tracks is required for installation.

3. SOLE PLATE

1. Position the leading edge of the sole plate (door width minus 9mm) away from the inside face of the rear studwork.

Sole Plate may need cutting down depending on door size.

2. Butt the sole plate centrally to the studwork at the back edge of the pocket.
3. Plumb true to the aluminium track above and secure the plate to the floor with appropriate fixings (**not supplied**).

For double kits repeat on other side

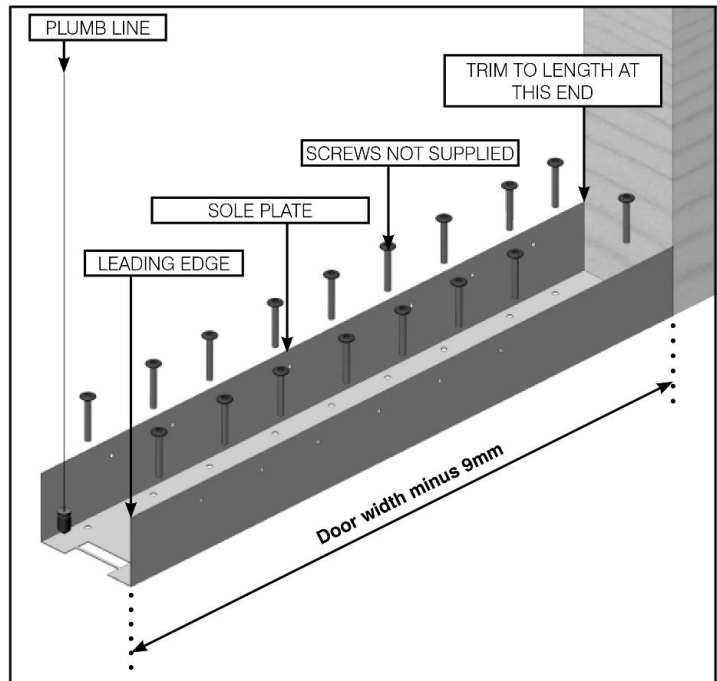

4. 'Z' PANELS

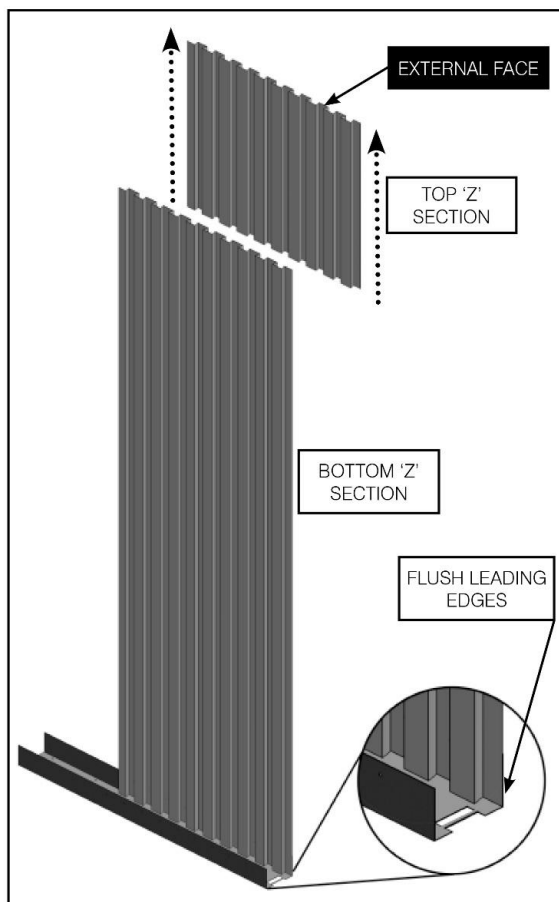

1. Extend the 'Z' Panels to desired height (inside surface of sole plate to underside of top studwork).

DO NOT DISSASSEMBLE 'Z' PANEL SHEETS

2. Position the bottom 'Z' Panel inside the sole plate so that both leading edges are flush.

MAKE SURE THE TOP 'Z' SECTION IS ON THE OUTSIDE OF THE POCKET

For intermediate, wide and double kits a second set of metal 'Z' panels are supplied. Fit only the first set at this stage.

On intermediate kits, the second set are narrower than the first set.

IF USING A REINFORCING KIT - PLEASE REFER TO INSTRUCTIONS 003-285 AND INSTALL IT AT THIS POINT BEFORE SCREW FIXING THE 'Z' PANELS

PLEASE NOTE: TOP 'Z' SECTION IS ON THE OUTSIDE OF THE POCKET

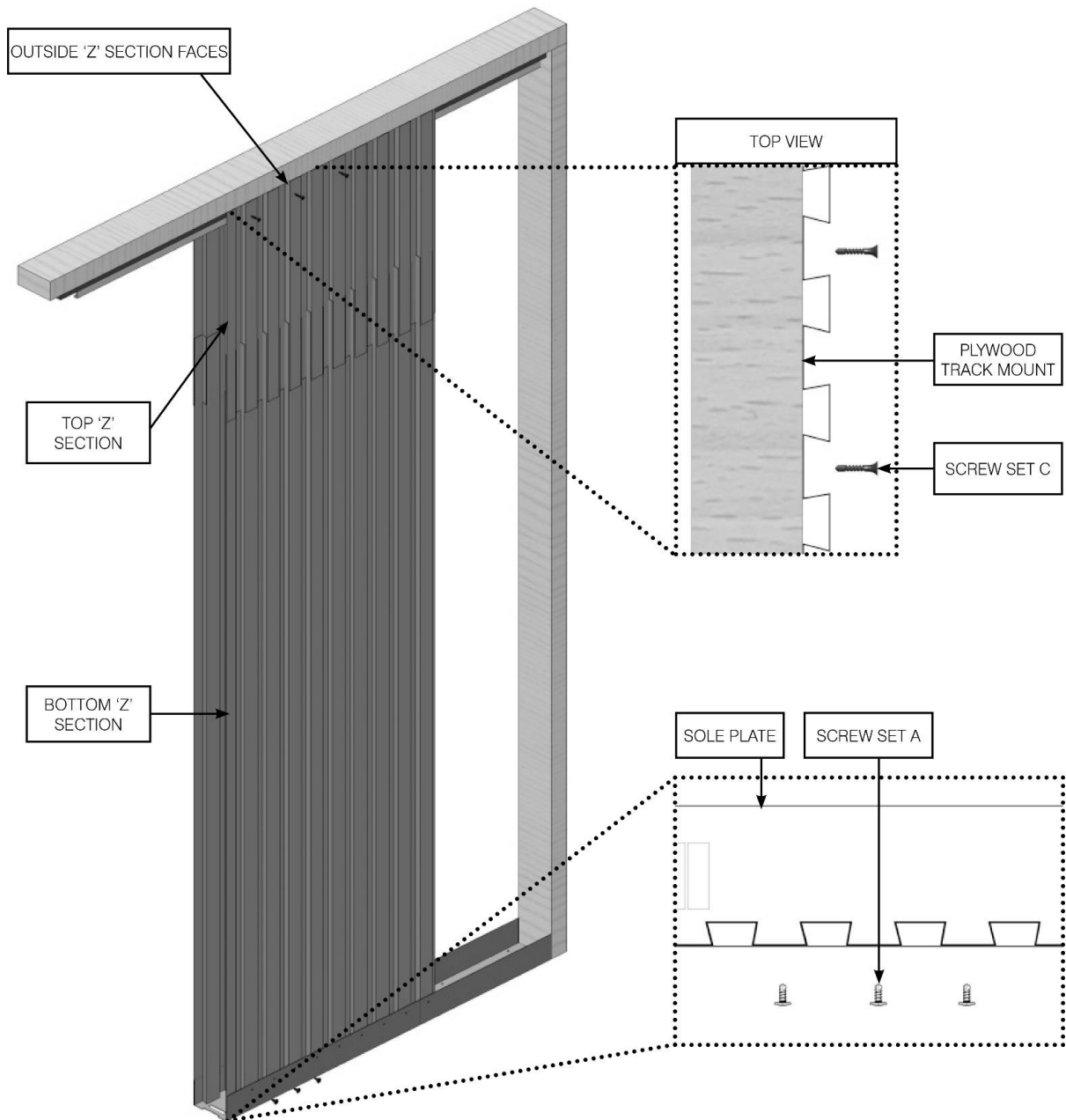

Ensure panels are level and then fix with screws.

1. Fix top 'Z' Section to plywood track mount with '**Screw Set C**'.
2. Fix bottom 'Z' section to sole plate with '**Screw Set A**'.

5. PANEL JOINING

1 2 3

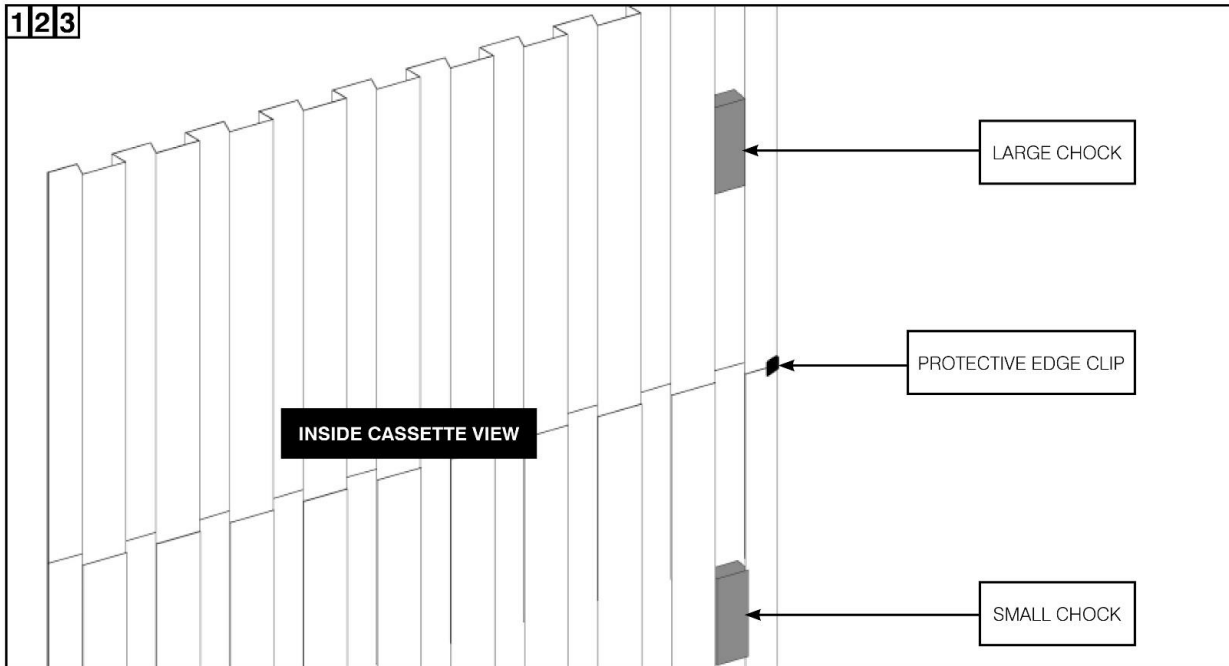

1. At the back of the pocket, place the protective edge clip onto the 'Z' section, covering where the panels join.
2. In the last 'Z' section slot towards the back of the inside pocket, push the large chock into the top 'Z' section and the two small chocks into the bottom 'Z' section. This pushes the edge outwards so the door does not snag on it when closing.

For intermediate and wide kits, fit chocks in the first and last slot in the rear 'Z' sections as detailed above
Fit protective edge clips on all joints on the rear 'Z' sections

3. Repeat stages 4 - 5 on the other side of the pocket.

For double kits repeat stages 4 - 5 to create the second pocket

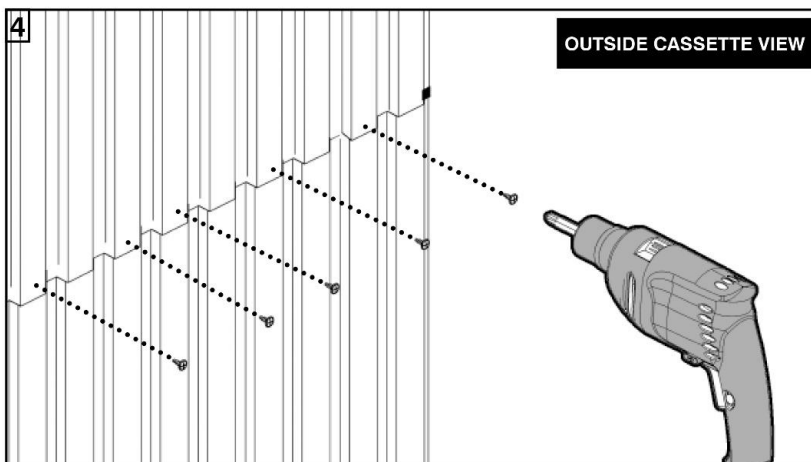

4. Pilot and screw through from outside to join panels together in five locations using 'Screw Set A'

**ENSURE SHEETS
DO NOT BECOME
BOWED WHEN
FIXING INTO PLACE**

6. TROLLEY INSTALLATION

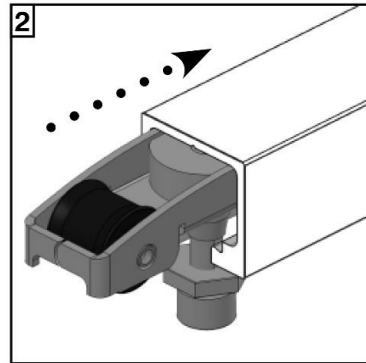
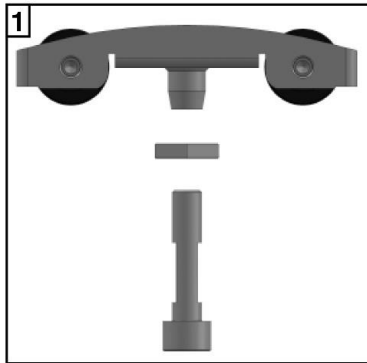

1. Assemble the trolley as pictured, screwing the bolt up into the trolley.
2. Slide both trolleys into the top rail at the front and back.

For double kits repeat for second track

7. DOOR GUIDE

1. Set the door guide to your glass width as shown in illustrations below .
2. Place the door guide inside the sole plate on the edge of the outer cut out and pencil mark all 3 hole positions.
3. Pilot drill the holes in preparation for screwing.
4. Fix the door guide in place using suitable countersunk screws to complete the installation.
(screws not provided)

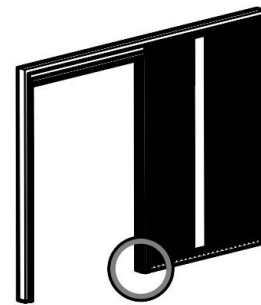

For double kits repeat for second sole plate

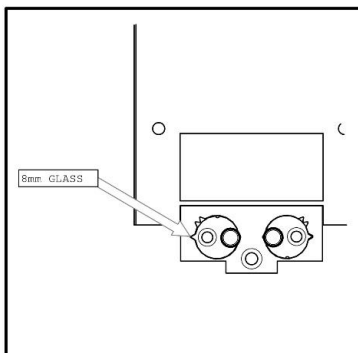

8mm Glass

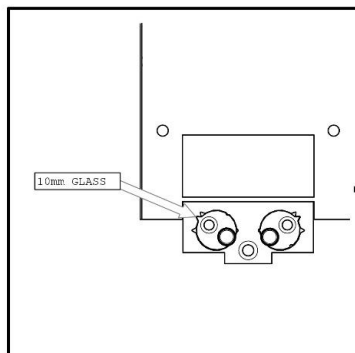

10mm Glass

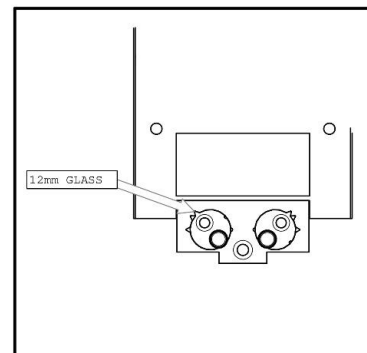

12mm Glass

8. GLASS CLAMP ASSEMBLY

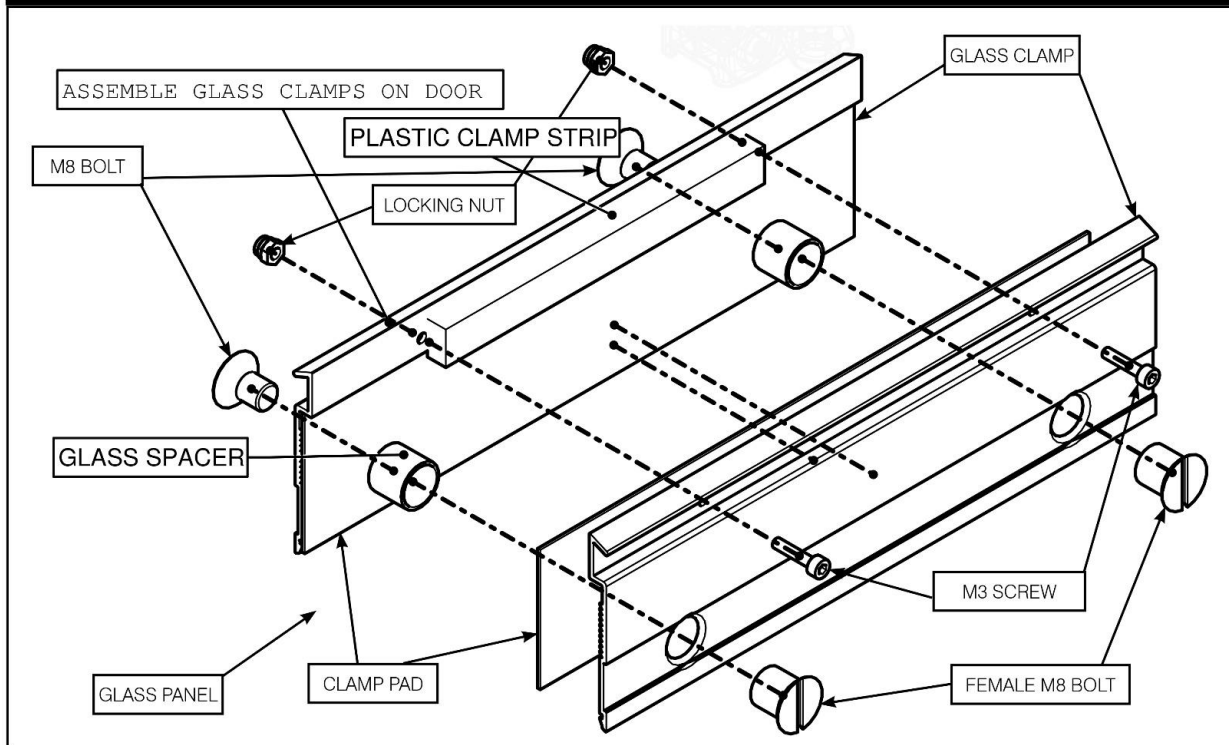

ENSURE YOUR GLASS IS DRILLED EXACTLY TO ROYDE AND TUCKER DRILLING SPECIFICATIONS FOR THIS KIT - DRILLING DETAIL ON FINAL PAGE OF DOCUMENT

Install the glass clamp assembly onto the upper side of the glass panel, as pictured above.

Ensure you use the correct fixings and number of glass seals for your glass thickness;

• 8mm - Clamp Pad	x 6
Glass Bush 8mm Wide	x 2

• 12mm - Clamp Pad	x 2
Glass Bush 12mm Wide	x 2

• 10mm - Clamp Pad	x 4
Glass Bush 8mm Wide	x 2

1. Ensure the glass bush is installed then loosely tighten the M8 Bolt into the female M8 Bolt.
2. Loosely tighten M3 Screw into the Locking Nut.
3. Now tighten the M8 Bolt followed by the M3 Screw. To ensure the M3 Screw is not over-tightened as this will cause the top of the Glass Clamp to curve inwards and affect operation, insert plastic clamp strip.

Repeat the procedure to install two clamps on the door
For double kits repeat for the other door

9. CUTTING THE VALANCE

1. The aluminium valance must be cut to match the width of door chosen +2mm. It is important the cuts are made square and should be done with a chop/mitre saw or similar.

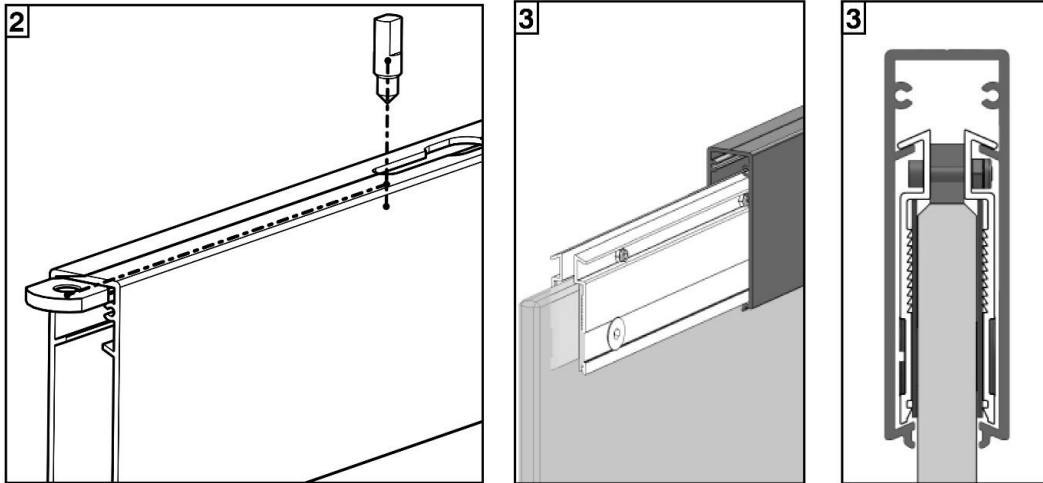

2. Insert clamp nut into top of aluminium valance and slide along to the first key hole slot. Insert clamp bolt through key hole and thread into clamp nut to locate - do not tighten at this stage.
3. Slide aluminium valance over both glass clamps to check fit and ensure clamps have not been overtightened and distorted.
4. Ensure the clamp nut and bolt are above the plastic glass clamp insert and tighten to locate glass centrally in the valance.

For double kits repeat for second door

10. INSTALLING THE DOOR

1. Position glass door with valance installed in opening
2. Pack the door (raise it up) so the valance sits just below the bolt head and line the bolt up with the large opening in the keyhole in the valance (use the second outer-most position).
3. Unscrew the bolt using the spanner provided until the bolt head is fully inside the rail slot and slide it across into the smaller section of the keyhole towards the centre of the door.
4. Screw the bolt upwards so it is tight on the underside of the top rail.
5. Repeat this process for the other trolley.
6. Remove the packing material you placed under the door so it now hangs free.
7. Adjust the bolts using the spanner to ensure the door is level and the bottom edge is **8 - 12mm** from the floor.
8. Screw the flat nuts down to lock everything in place with the large spanner provided.
9. Install capping plate to the end of the valance using small self tapping screws provided

For double kits repeat for second door

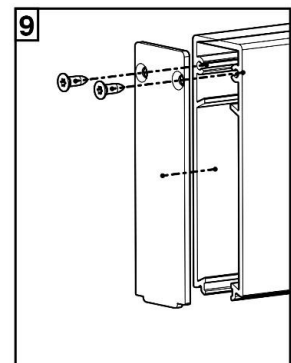
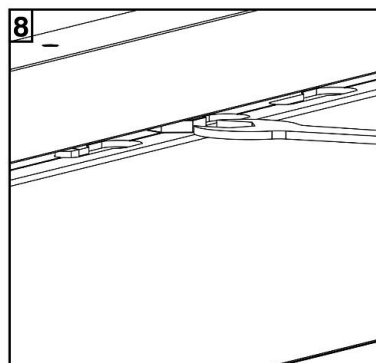
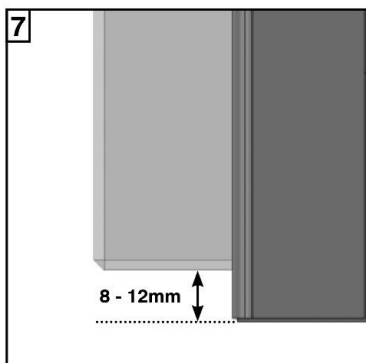
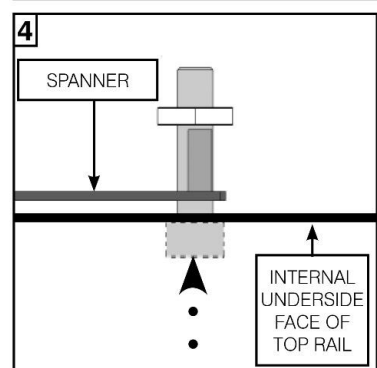
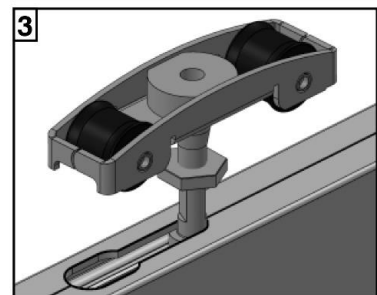
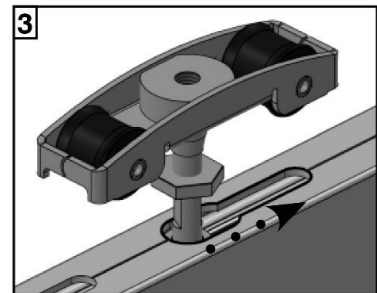
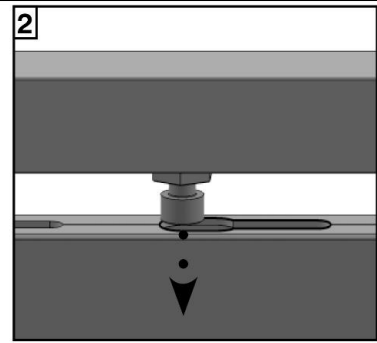

11. JAMB FITTING - CASSETTE JAMBS

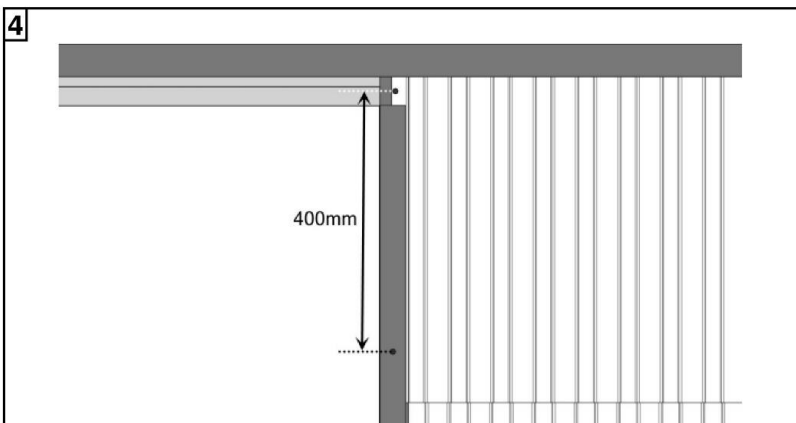
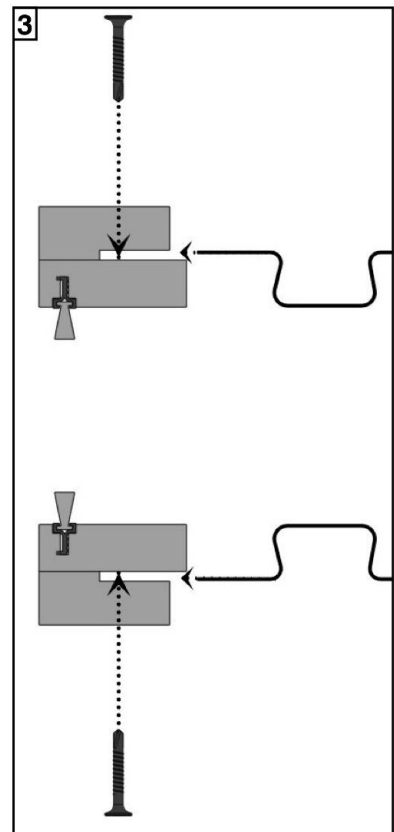
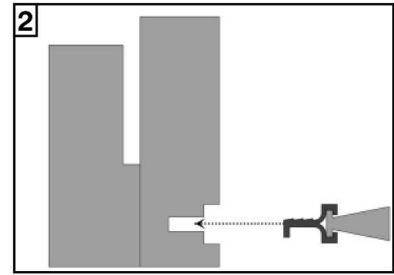
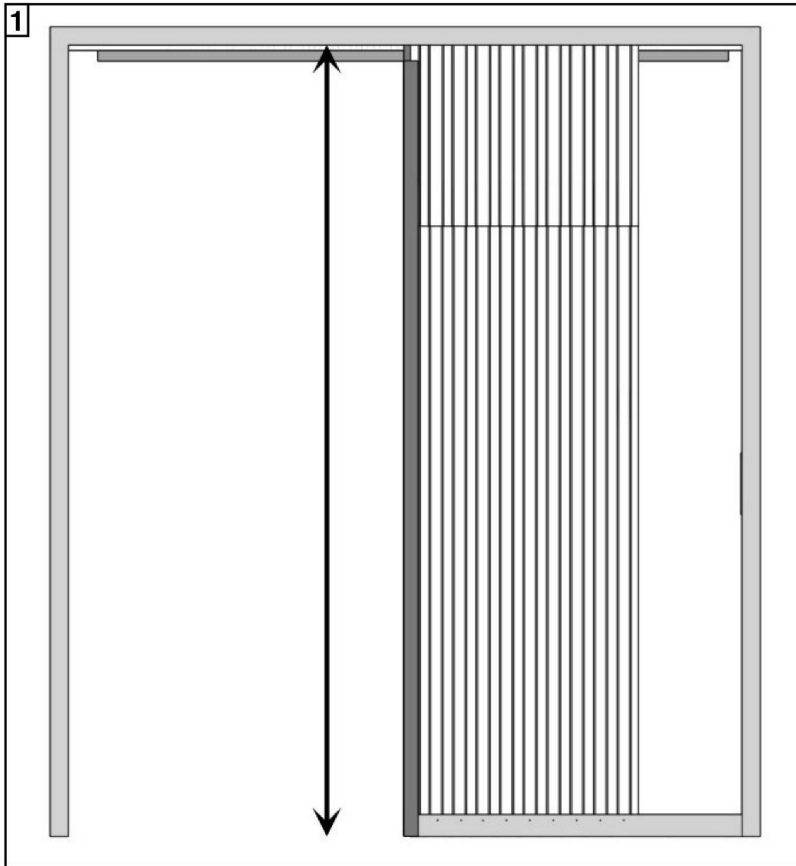

1. Cut cassette jambs to the studwork height from the finished floor to the underside of the stud. Ensure any cut is made at the end without the notch detail.
2. Push fit the brush seals into all cassette jambs.
3. Press the jambs onto the edges of the 'Z' Sections and secure with 'Screw Set C'.
4. Screw at the top and bottom and then approximately every 400mm.

12. TRACK PACKERS

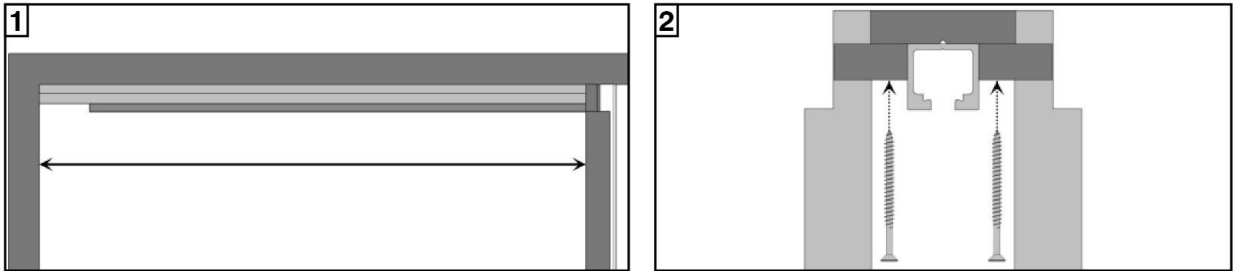

1. To cut the track packers, measure remaining door opening width between the cassette edge jamb and the studwork.

For double kits, measure between the cassette edge jamb of one pocket and the other

2. To secure the track packers, first pilot and countersink a series of holes in their length, approximately 300mm apart. Screw through into the plywood track mount using **'Screw Set E'**.

13. JAMB FITTING - FRONT EDGE JAMBS

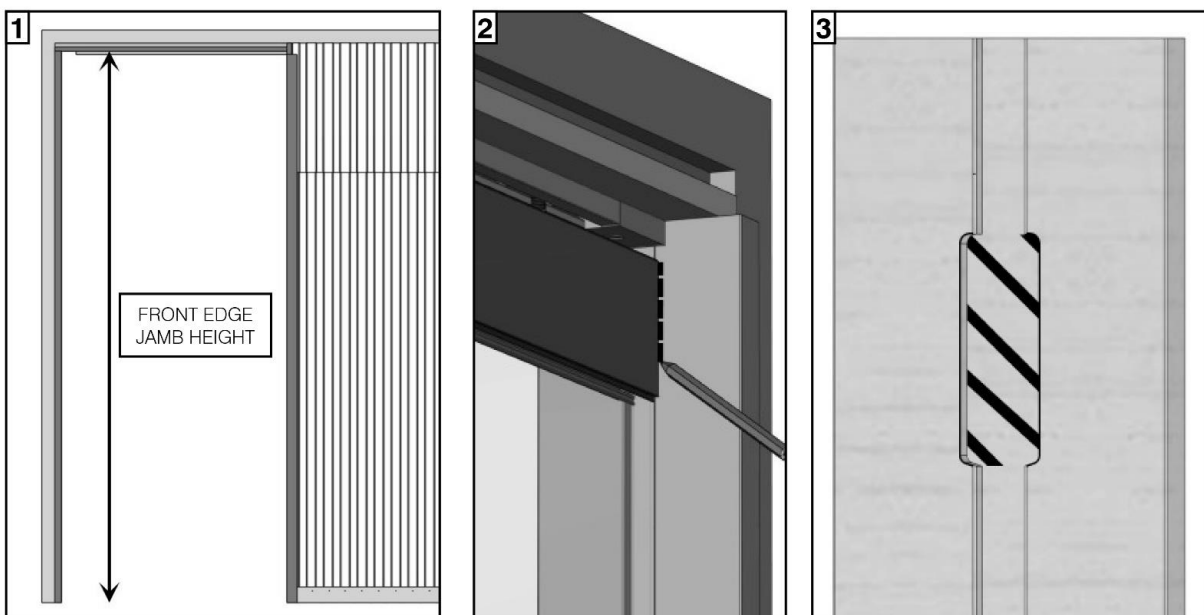

1. Using a sawing or cutting tool, cut the front edge jamb lengths to fit from the floor to the underside of the track packers.
2. Slide the door to its closed position to test fit and to mark around with a pencil where the top rail touches the jamb. The area you have marked will be routed away so the whole door can close flush.
3. Routing just outside the drawn lines, cut to the same depth as the channel already in the wood. Close the door again to test the fit and then screw the jamb in place.

For double kits discard this step

14. DOOR STOPS

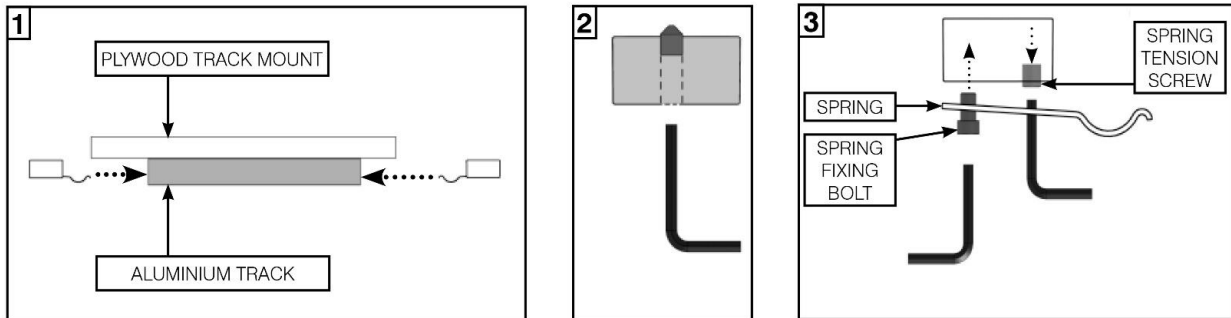

1. Place trolley catches at the front and back of the aluminium track (If not done already).
2. Fix trolley catches in required positions within the aluminium track by removing the spring giving access to the centre hole locking grub screw, use the provided 3mm allen key.
3. Replace the spring and adjust the clamping bolt to the desired tension to hold the trollies in place, use the provided 4mm allen key.

For double kits repeat for second track

INTERMEDIATE AND WIDE KITS

Fit the second set of 'Z' section sheets so that the rear edge is inline with the back of the pocket.

15. END BLOCK

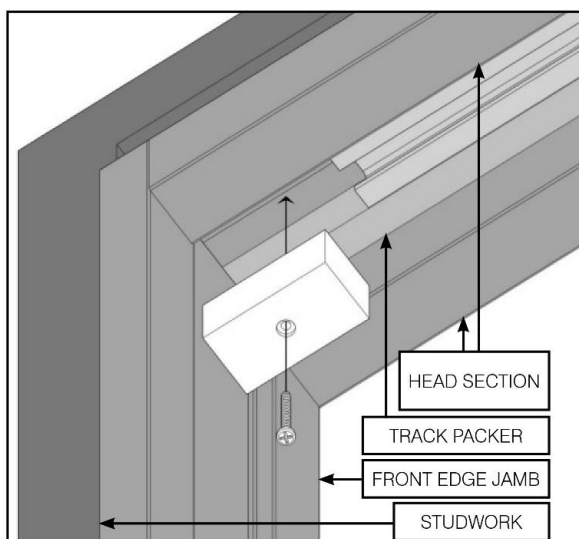

1. Pilot drill and counterbore a hole in the wooden end block using a 2mm drill bit. Drill the hole in the centre of the block.
2. Using the newly made hole, with '**Screw Set D**', screw into the 82mm spacing left between the aluminium track and the studwork. Make sure the end block is butted against the track.

For double kits replace end block into central space

16. PLASTERBOARD

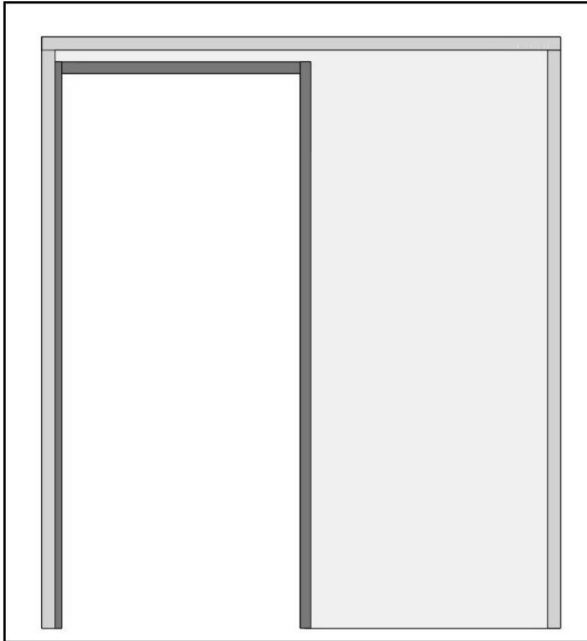

1. Clad the kit in 12.5mm of plasterboard. Ensure it butts up level and tight against all jambs.

When positioned correctly, use screw fixings to secure to the stud frame.

2. Pilot drill through the plasterboard and 'Z' section sheets a maximum of 300mm apart vertically and horizontally equal.

Screw the plasterboard into place.
(fixings not included)

**ENSURE NO SCREWS PROTRUDE
INTO THE POCKET CAVITY**

PORTMAN

GLASS DRILLING DETAILS FOR PG926 & PG1500

Please Note: 50mm Diameter hole only for optional P7950 and P7951 flush pulls

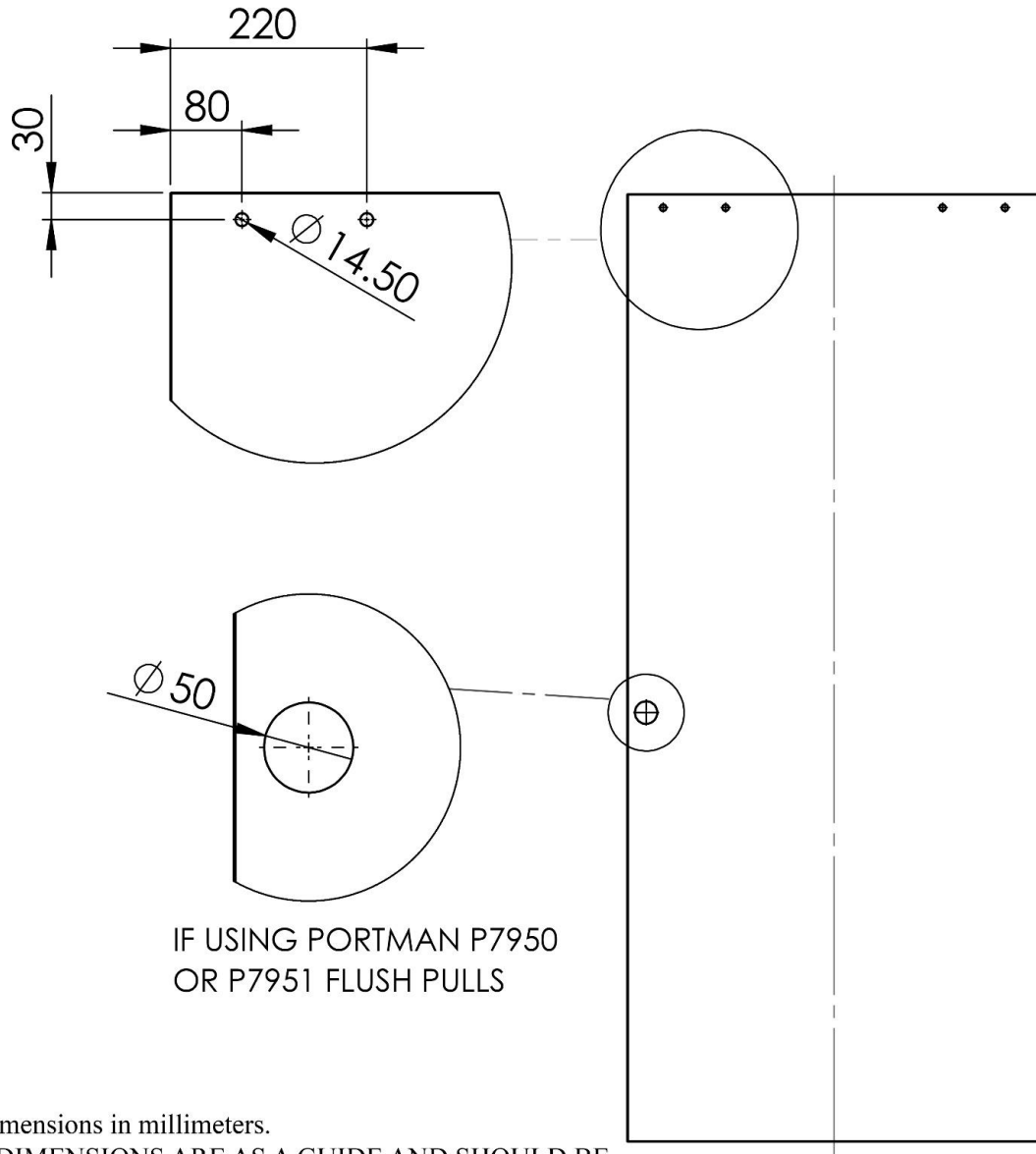

All dimensions in millimeters.
ALL DIMENSIONS ARE AS A GUIDE AND SHOULD BE
CHECKED WITH THE GLASS DOOR MANUFACTURER.

NOTE; A NARROW STRESS RELIEF SLOT MAY BE REQUIRED FROM THE RIM
OF THE HOLES TO THE TOP EDGE WITH SOME GLASS TYPES. CHECK WITH
GLASS DOOR MANUFACTURER.