

Planung und Montage

Beschlag für 2 Holzschiebetüren bis 80 kg, gleichzeitig nach links und rechts öffnend.

Planification et montage

Ferrure pour 2 portes coulissantes en bois jusqu'à 80 kg, ouvrant simultanément à gauche et à droite.

Planning and installation

Hardware system for 2 wooden sliding doors up to 80 kg (176 lbs.), simultaneously opening to the left and right.

Pianificazione e montaggio

Ferramenta per 2 porte scorrevoli in legno fino a 80 kg, per aprire contemporaneamente a sinistra e a destra.

Planificación y montaje

Herraje para apertura simultánea de 2 puertas deslizantes de madera a derecha e izquierda, para pesos de puerta hasta 80 kg.

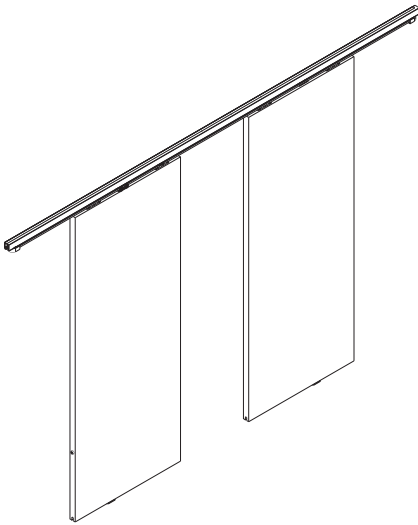

■ Hawa-Teile ■ Eléments Hawa ■ Hawa components ■ Componenti Hawa ■ Componentes Hawa

Metric specifications are exact - Inches are approximate

Diese Zeichnung ist Eigentum der Hawa AG und darf weder verwertet, vervielfältigt noch Dritten zugänglich gemacht werden. Alle unsere Katalog-Zeichnungen sowie die speziellen Einbauzeichnungen im Massstab 1:1 usw. stellen Beispiele zum Einbau unserer Beschläge dar. Irgendwelche Ansprüche aus der Verwendung dieser Unterlagen können durch den Kunden nicht abgeleitet werden. Für bau-/projektbezogene, konstruktive Details wird keine Verantwortung übernommen.

Ce plan est la propriété de Hawa AG. Il ne peut être utilisé à titre lucratif, ni photocopié ou transmis à un tiers. Tous les plans publiés dans les catalogues, les plans de montage spéciaux à l'échelle 1:1 etc. représentent des exemples de montage de nos ferrures. Le client ne peut tirer des droits quelconques en utilisant de tels documents. Pour des détails constructifs touchant aux projets ou aux sites, toute responsabilité est déclinée.

This drawing remains the property of Hawa AG and may not be sold, reproduced or made available to third parties. All of our catalogue drawings and special full scale installation drawings etc. represent installations using our hardware and fittings. No claims on the part of the customers can be considered which arise in connection with the use of these documents. For site or project-related design details any liability is declined.

Questo disegno è proprietà di Hawa AG e non può essere usato a scopo di lucro, riprodotto e reso accessibile a terzi. Tutti i nostri disegni del catalogo nonché i particolari disegni di montaggio in scala 1:1 ecc. rappresentano esempi per il montaggio delle nostre ferramenta. Eventuali rivendicazioni a seguito dell'utilizzo di questa documentazione non possono essere evidenziate da parte del cliente. Non assumiamo nessuna responsabilità per dettagli costruttivi che riguardano qualsiasi costruzione o progetto.

Este documento es propiedad de la empresa Hawa AG. Se excluye la venta y reproducción, al igual que el acceso a terceras personas. Los planos contenidos en nuestros catálogos, al igual que los planos especiales de montaje a escala 1:1 etc. representan ejemplos para el montaje de nuestros herrajes. Su uso no implica la deducción de derechos, cualquiera sea su naturaleza, por parte del cliente. No asumimos ninguna responsabilidad por los detalles constructivos relativos a la construcción o proyectos.

<h1>20663</h1>	<h1>a</h1>	Gezeichnet/Dessiné/Drafted/Disegnato/Dibujado 10.2005 / Jürg Stettler	Internationale Schutzrechte Änderungen vorbehalten Droits internationaux déposés Sous réserve de modifications Swiss and foreign patents Design subject to modification Diritti protettivi internazionali Con riserva di apportare modifiche Derechos internacionales protegidos Planos sujetos a modificaciones
		Änderung/Modification/Modification/Modificazione/Modificación 11.2007 / Jürg Stettler	
		Ersetz/Remplace/Replaces/Sostituisce/Reemplaza 20663-	
		Visum/Visa/Visa/Visto/Visado 11.2007 / Felix Meili	



Deutsch

HAWA-Symmetric 80/Z

Maximales Türgewicht 80 kg
Minimale Türbreite 500 mm
Maximale Türbreite 1200 mm

Français

HAWA-Symmetric 80/Z

Poids maximum par porte 80 kg
Largeur minimum par porte 500 mm
Largeur maximum par porte 1200 mm

English

HAWA-Symmetric 80/Z

Maximum door weight 80 kg (176 lbs.)
Minimum door width 500 mm (1'7 $\frac{11}{16}$ ")
Maximum door width 1200 mm (3'11 $\frac{1}{4}$ ")

Italiano

HAWA-Symmetric 80/Z

Peso massimo della porta 80 kg
Larghezza minima della porta 500 mm
Larghezza massimo della porta 1200 mm

Español

HAWA-Symmetric 80/Z

Peso máximo de puerta 80 kg
Ancho mínimo de puerta 500 mm
Ancho máximo de puerta 1200 mm

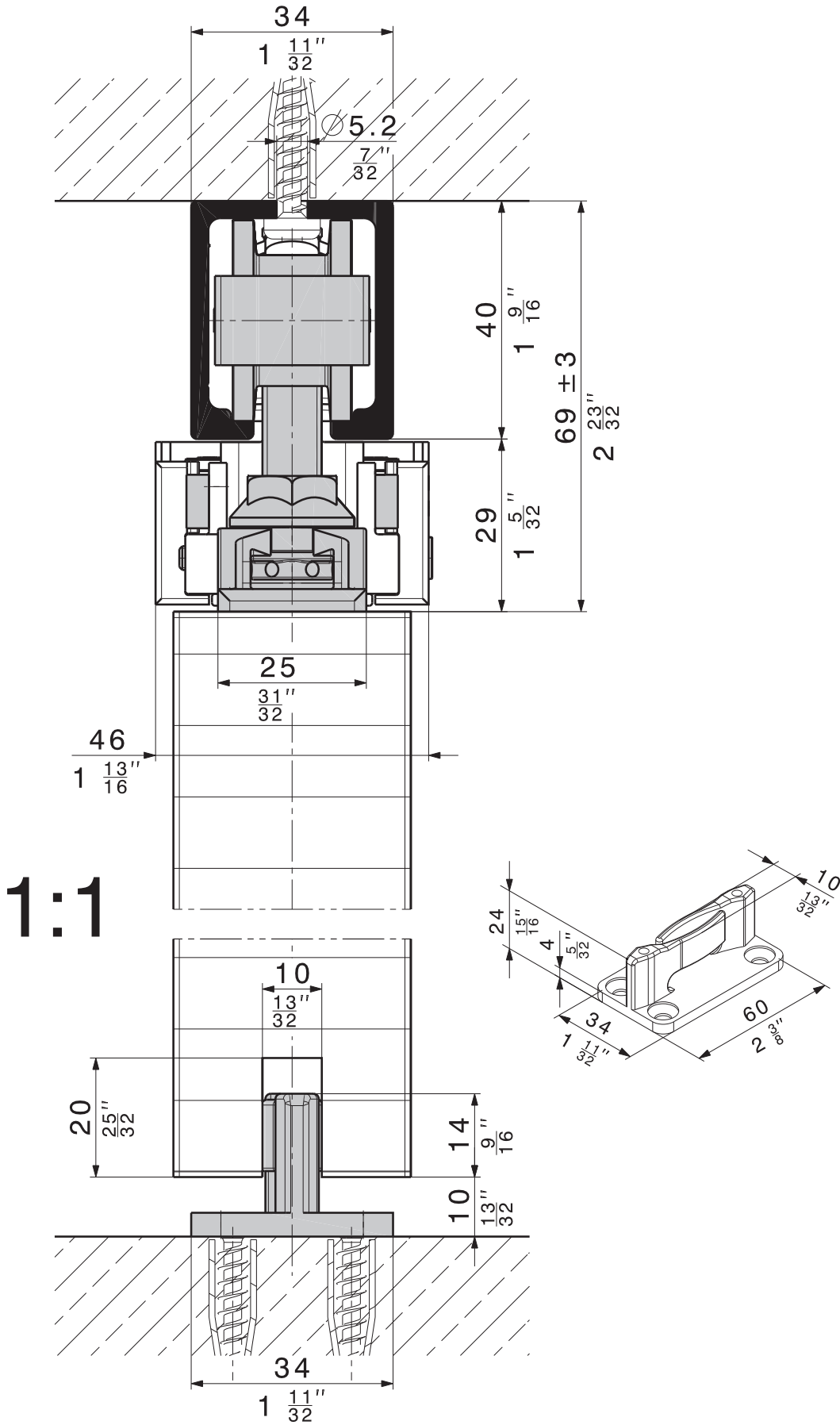

Technische Änderungen vorbehalten
 Sous réserve de modifications techniques
 Subject to modification

Ci si riserva di apportare modifiche tecniche
 Bajo reserva de modificaciones técnicas

HAWA - Symmetric 80/Z

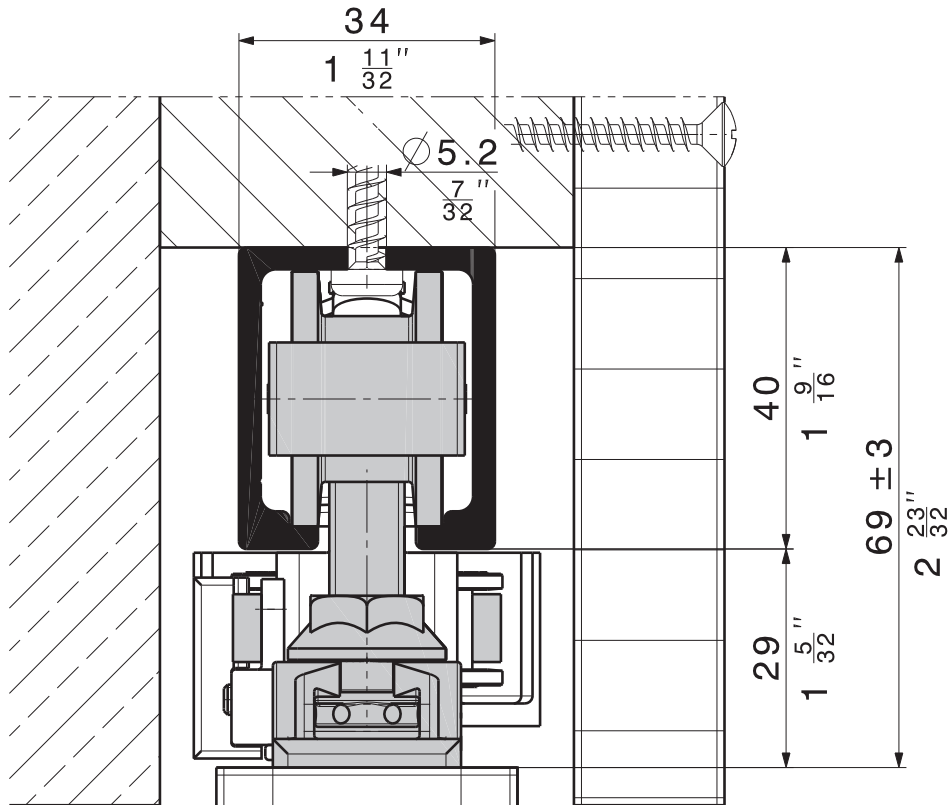

1:1

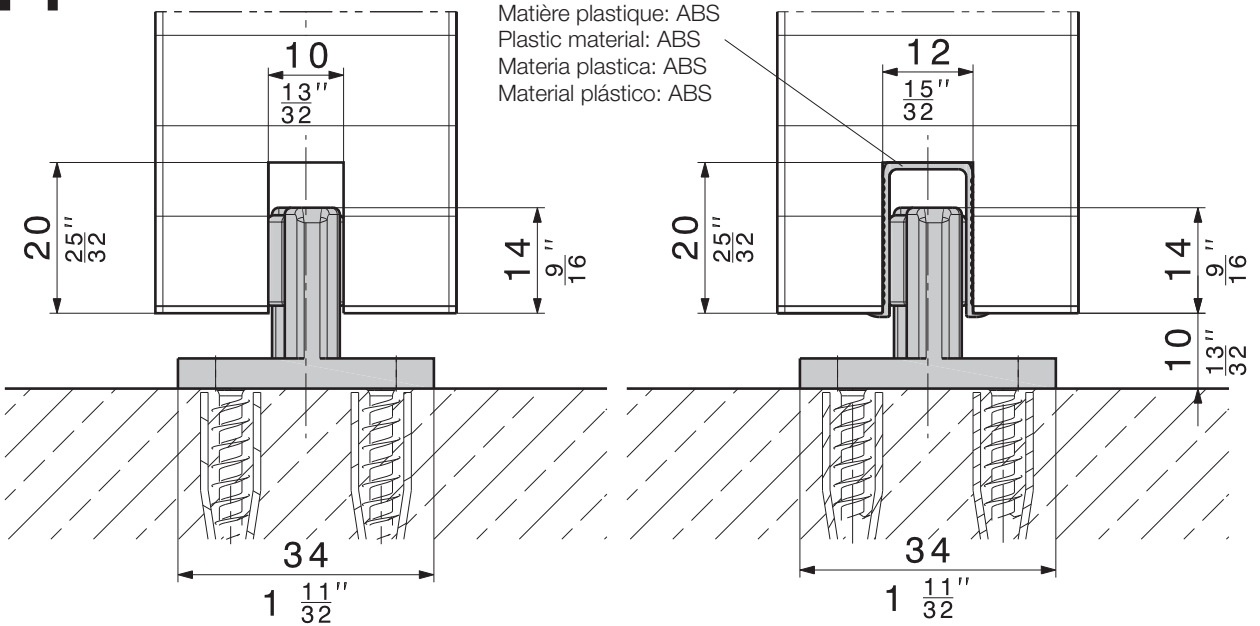

Kunststoffmaterial: ABS
 Matière plastique: ABS
 Plastic material: ABS
 Materia plastica: ABS
 Material plástico: ABS

Technische Änderungen vorbehalten
 Sous réserve de modifications techniques
 Subject to modification

Ci si riserva di apportare modifiche tecniche
 Bajo reserva de modificaciones técnicas

*Zweiwegaufhängung
Suspension à deux voies
Two-way suspension plate
Suspensione a due vie
Suspensión a dos vías*

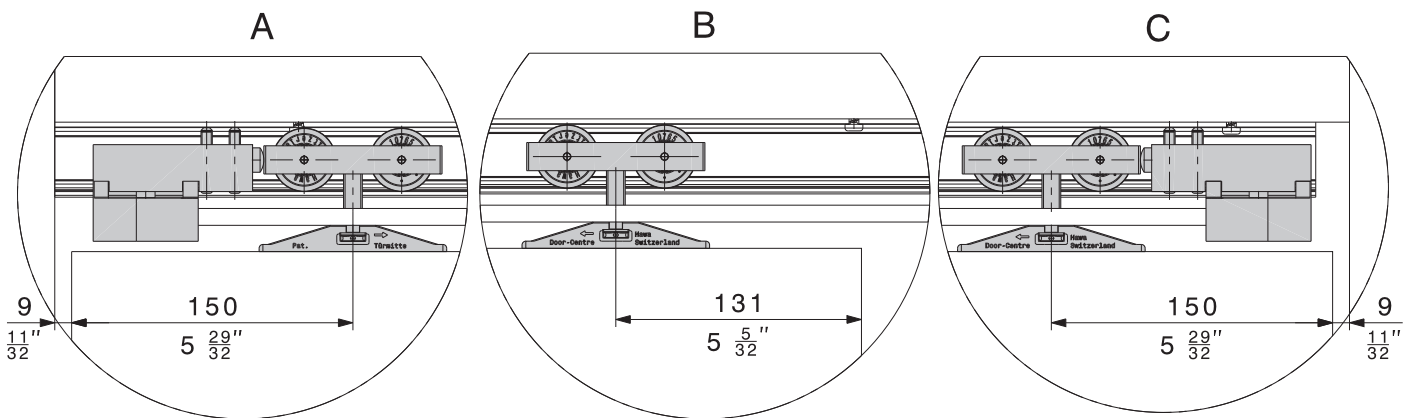
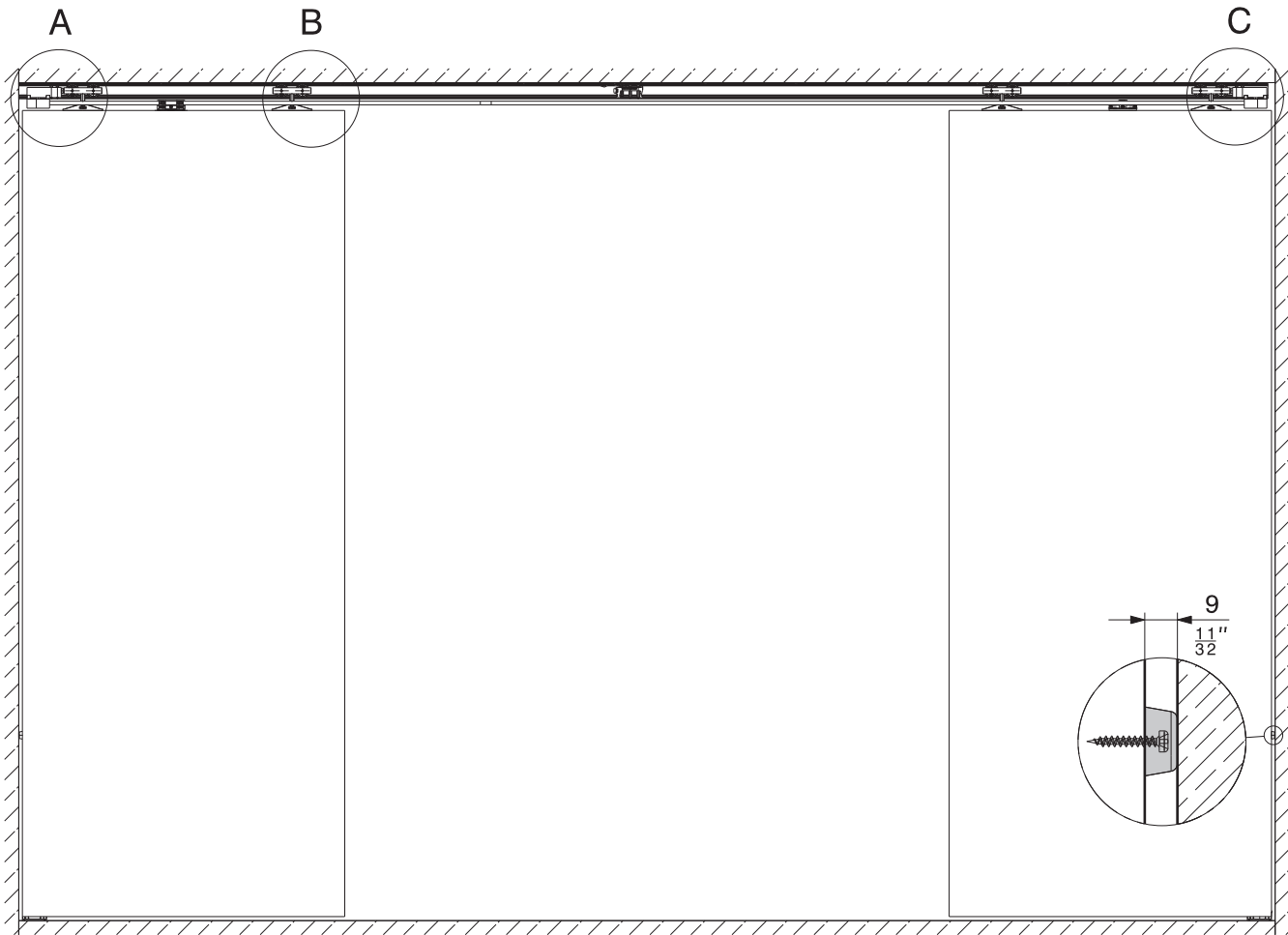

Technische Änderungen vorbehalten
Sous réserve de modifications techniques
Subject to modification

Ci si riserva di apportare modifiche tecniche
Bajo reserva de modificaciones técnicas

Montage Laufschiene
Montage du rail de roulement
Mounting of top track
Montaggio rotaia
Montaje del riel de rodadura

Vor dem Bestücken die Laufschiene reinigen.
Nettoyer le rail de roulement avant son garnissage.
Clean the track before fitting components.
Pulire la rotaia prima di equipaggiarla.
Limpiar el riel antes de colocar los componentes.

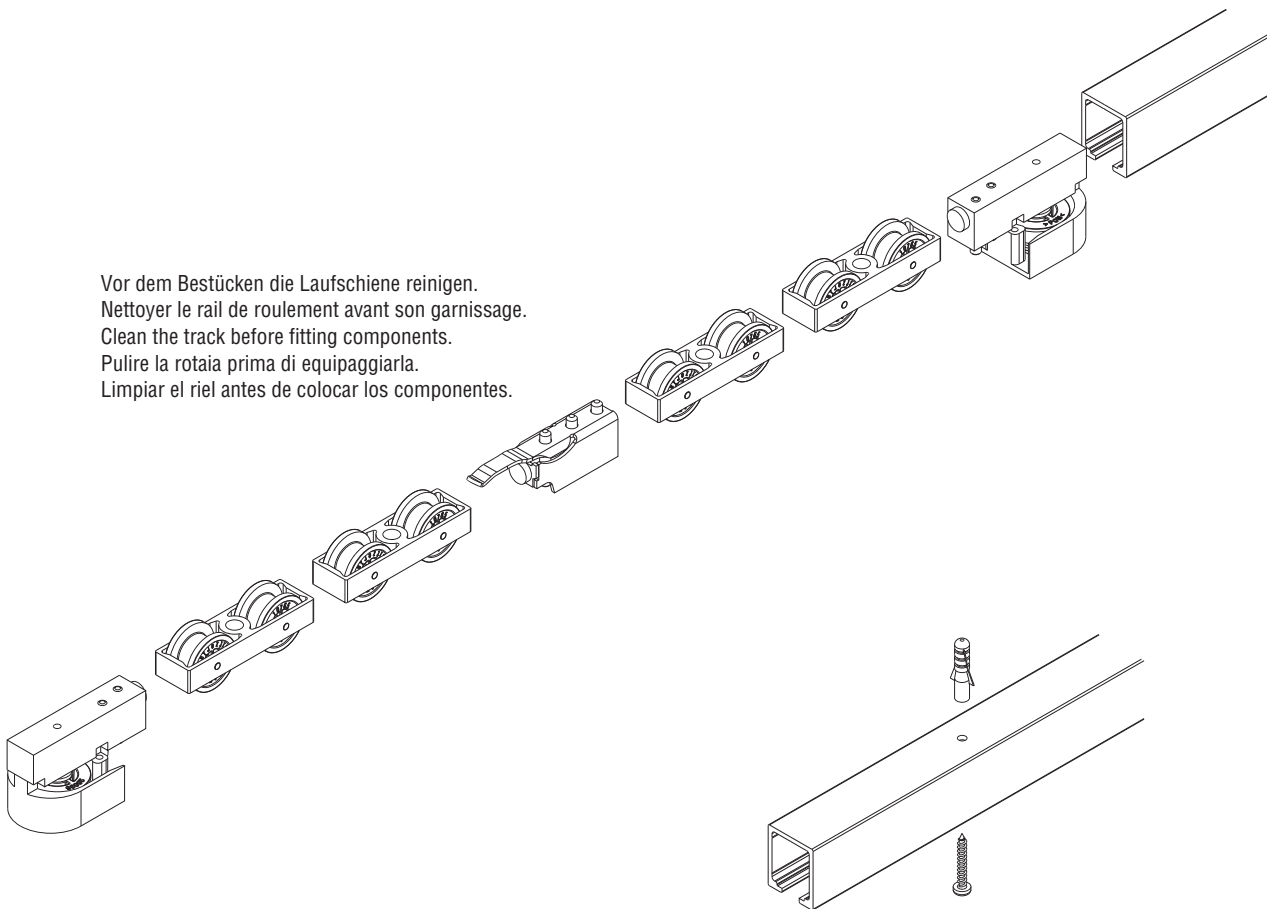

Technische Änderungen vorbehalten
Sous réserve de modifications techniques
Subject to modification

Ci si riserva di apportare modifiche tecniche
Bajo reserva de modificaciones técnicas

Vormontage Schiebetüren
Pré-montage portes coulissantes
Pre-assembly of sliding doors
Premontaggio porte scorrevoli
Montaje previo puertas deslizantes

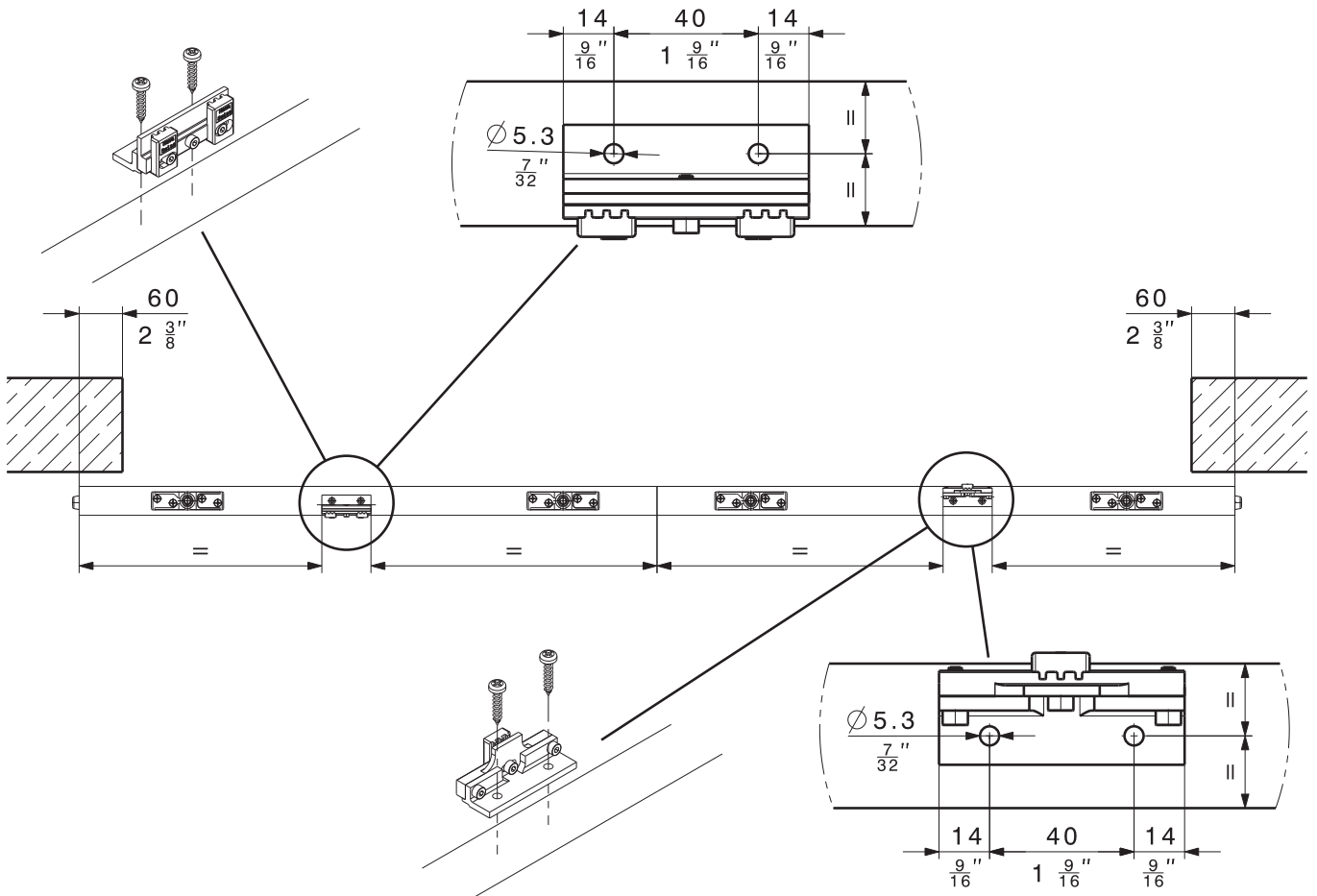
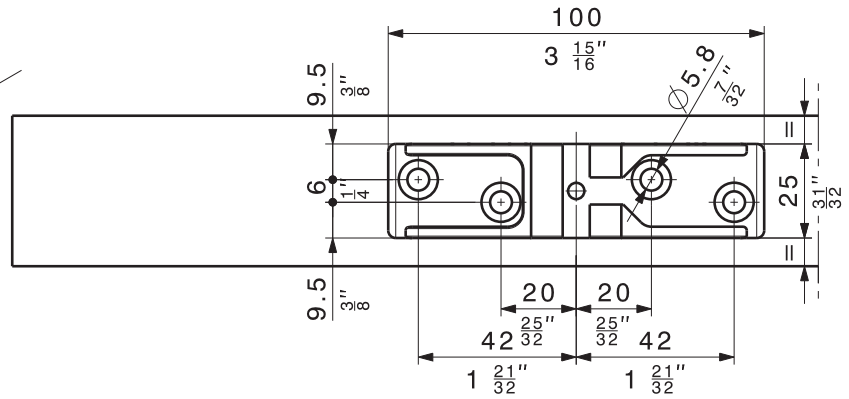
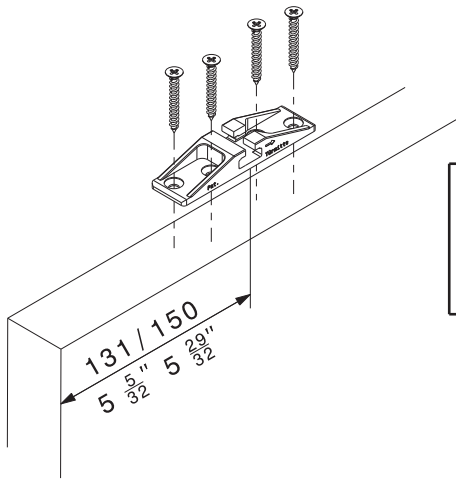

Technische Änderungen vorbehalten
 Sous réserve de modifications techniques
 Subject to modification

Ci si riserva di apportare modifiche tecniche
 Bajo reserva de modificaciones técnicas

Montage Schiebetüren und Zahnriemen
Montage portes coulissantes et de la courroie dentée
Assembly of sliding doors and toothed belt
Montaggio porte scorrevoli e della cinghia dentata
Montaje de puertas deslizantes y correas dentadas

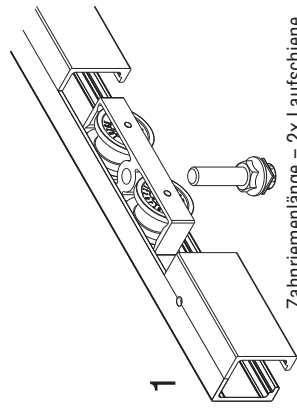

Zahnriemenlänge = 2x Laufschiene
 Longueur de la courroie dentée = 2 x rail de roulement
 Length of toothed belt = 2 x top track
 Lunghezza cinghia dentata = 2 x rotaia
 Largo de la correa de tracción = 2x riel de rodadura

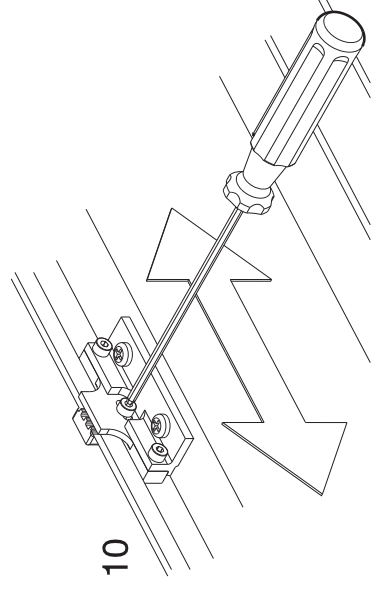
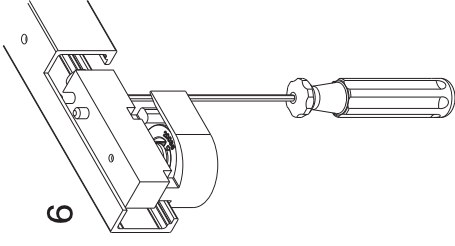
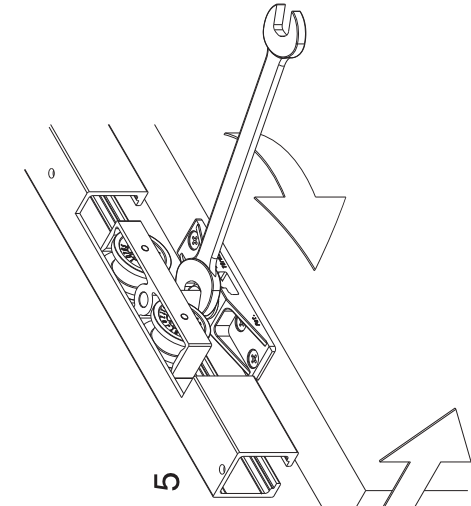
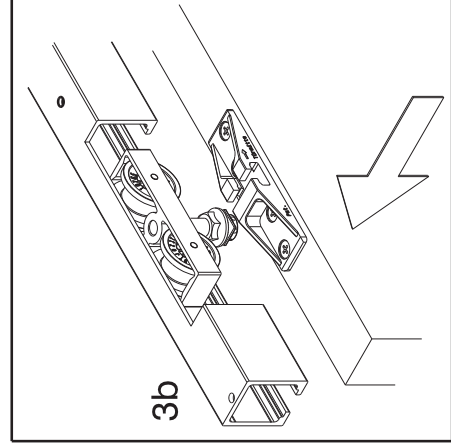
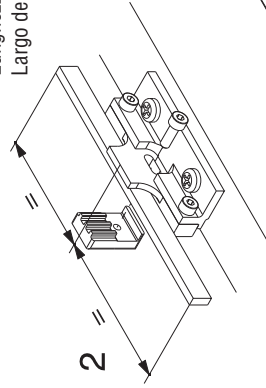

Schiebetüren positionieren
 Positionnement des portes coulissantes
 Positioning the sliding doors
 Posizionamento porte scorrevoli
 Posicionar puertas deslizantes

Zahnriemenzähne aussen
 Dents de la courroie dentée à l'extérieur
 Toothed belt teeth on outer side
 Cinghia dentata a denti esterni
 Dientes de la correa de tracción hacia el lado exterior

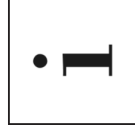
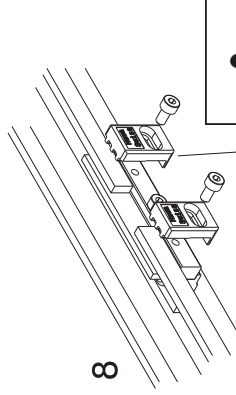
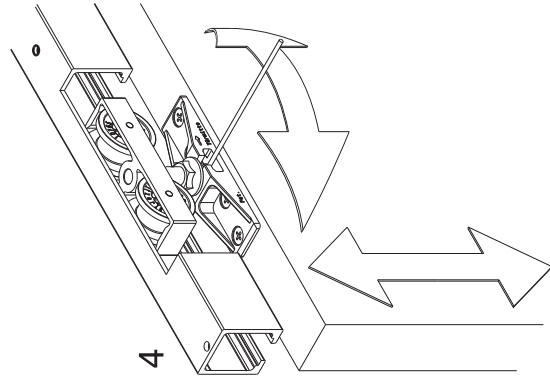

Voraussetzung für ein einwandfreies Funktionieren der Anlage ist ein leicht gespannter Zahnriemen.
 Une courroie dentée légèrement tendue est un préalable au fonctionnement impeccable de l'installation.
 The toothed belt must be slightly tensioned in order for the system to function properly.
 La tensione leggera della cinghia dentata è il presupposto per il funzionamento ineccepibile del sistema.
 La correa de tracción requiere ser ligeramente tensada para permitir un correcto funcionamiento del sistema.

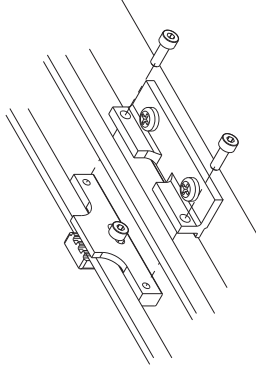
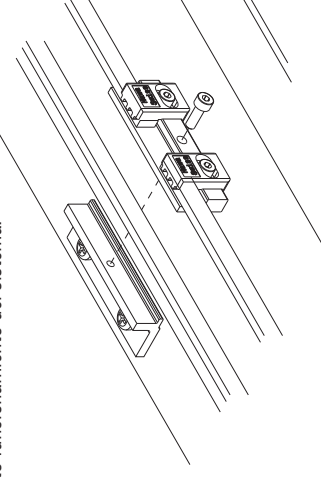
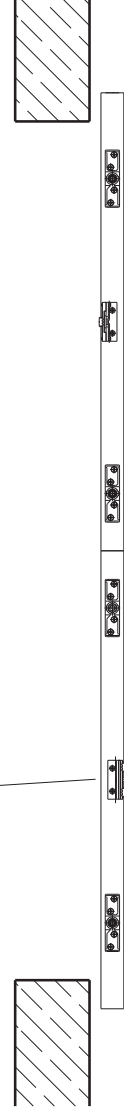

Technische Änderungen vorbehalten
 Sous réserve de modifications techniques
 Subject to modification

Ci si riserva di apportare modifiche tecniche
 Bajo reserva de modificaciones técnicas

Hawa AG CH-8932 Mettmenstetten Tel. +41 44 767 91 91 Fax +41 44 767 91 78
 www.hawa.ch

Technische Änderungen vorbehalten
 Sous réserve de modifications techniques
 Subject to modification

Hawa AG CH-8932 Mettmenstetten Tel. +41 44 767 91 91 Fax +41 44 767 91 78
 www.hawa.ch

Position und Montage des Schienenpuffers
Position et montage de la butée de rail
Position and mounting of track stop
Posizione e montaggio del paracolpi
Posición y montaje del tope de riel

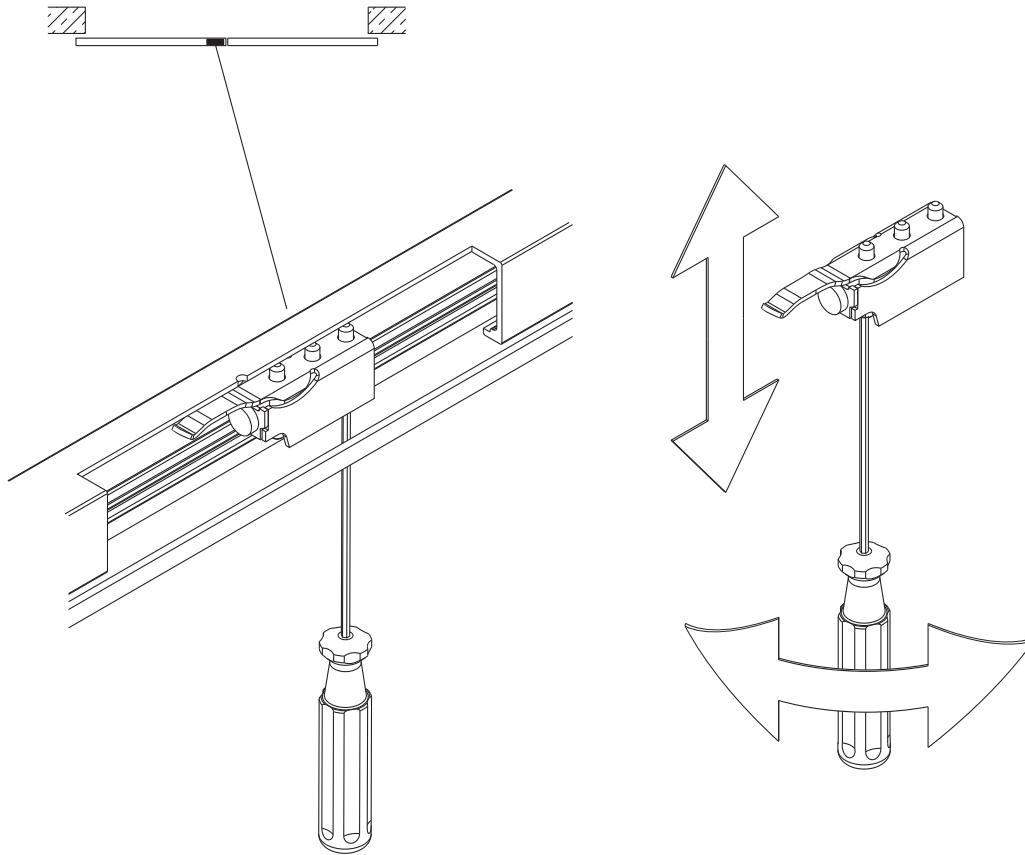



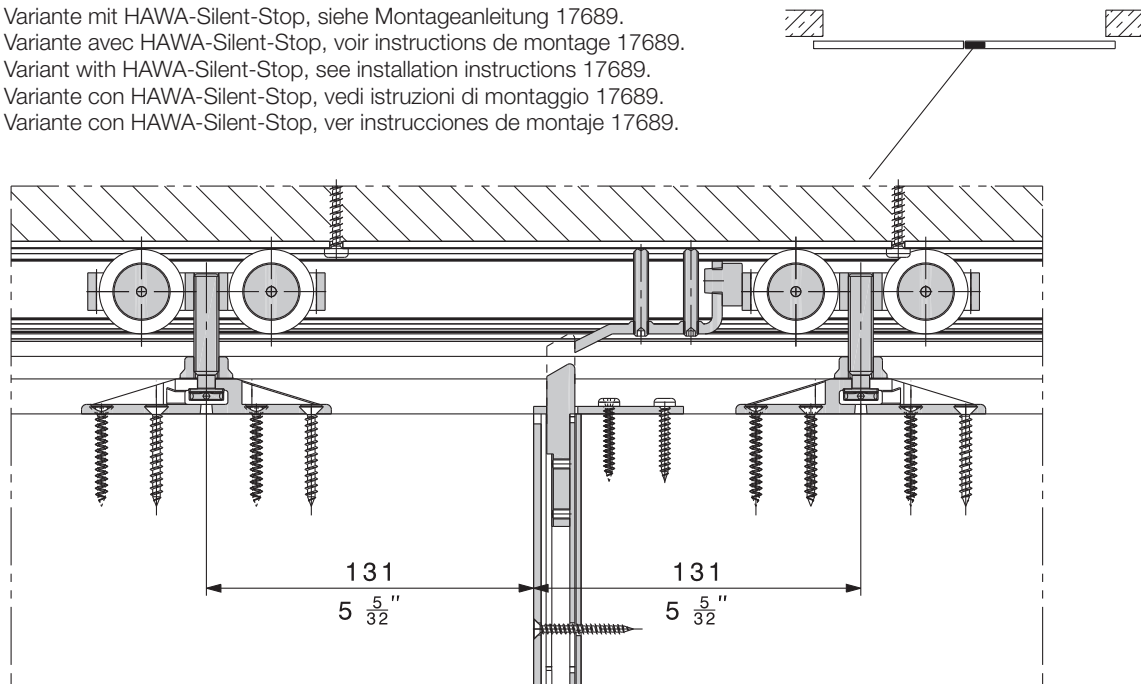



Variante mit HAWA-Silent-Stop, siehe Montageanleitung 17689.
 Variante avec HAWA-Silent-Stop, voir instructions de montage 17689.
 Variant with HAWA-Silent-Stop, see installation instructions 17689.
 Variante con HAWA-Silent-Stop, vedi istruzioni di montaggio 17689.
 Variante con HAWA-Silent-Stop, ver instrucciones de montaje 17689.



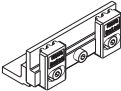
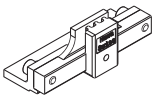
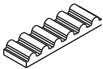
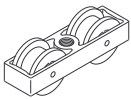

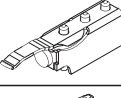
Technische Änderungen vorbehalten
 Sous réserve de modifications techniques
 Subject to modification

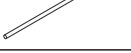
Ci si riserva di apportare modifiche tecniche
 Bajo reserva de modificaciones técnicas

Beschlägeübersicht
Composants de la ferrure
Hardware system components
Assortimento ferramenta
Componentes de los herrajes

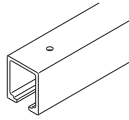
	20653
	20352
	20353
	19668
	10407
	10489
	10628
	14427
	10795
	10629

	1400 mm (4'7 $\frac{1}{8}$ ")	10189
	1600 mm (5'3)	10190
	1800 mm (5'10 $\frac{7}{8}$ ")	10191
	2000 mm (6'6 $\frac{3}{4}$ ")	10192
	2200 mm (7'2 $\frac{5}{8}$ ")	10193
	2500 mm (8'2 $\frac{7}{16}$ ")	10194
	3000 mm (9'10 $\frac{1}{8}$ ")	18532
	4000 mm (13'1 $\frac{1}{2}$ ")	18533
	6000 mm (19'8 $\frac{7}{32}$ ")	10186
	nach Mass sur mesure cut to size su misura a medida	10188
Set à 10 Stück Jeu à 10 pièces 10-pieces set Set da 10 pezzi Juego de 10 piezas	1300 mm (4'3 $\frac{3}{16}$ ")	14540

Technische Änderungen vorbehalten
 Sous réserve de modifications techniques
 Subject to modification

Ci si riserva di apportare modifiche tecniche
 Bajo reserva de modificaciones técnicas